

Installation Manual
(original instructions)

EN

Panasonic[®]

N421118A - Rev. 01 - 10/2024

Aquarea Air - Floor Standing

P-FAL** series

First of all, we would like to thank you for having chosen a device of our production.

We are sure you will be happy with it because it represents the state of the art in the technology of home air conditioning.

By following the suggestions contained in this manual, the product you have purchased will provide trouble free operation, giving you optimum room temperatures with minimum energy costs.

Panasonic Corporation

Conformity

This unit complies with the European directives:

- Low voltage 2014/35 / EU
- Electromagnetic compatibility 2014/30 / EU
- RoHS 2011/65/UE
- Regulation (EU) No. 2016/2281 implementing Directive 2009/125/EC

Markings



TABLE OF CONTENTS

1. Coding	4	7. Technical information	31
1.1 Product related coding	4	7.1 Technical data.	31
2. General information	5	7.2 Operating limits	32
2.1 About the manual	5	7.3 Dimensions	32
2.2 General warnings	6	7.4 Installation template	33
2.3 Basic rules of security	6		
2.4 Disposal	7		
3. Product presentation	8		
3.1 Identification	8		
3.2 Destination of use	8		
3.3 Description of the appliance	8		
3.4 Components.	9		
3.5 Compatible accessories	10		
4. Installation	12		
4.1 Preliminary warnings	12		
4.2 Reception	12		
4.3 Dimensions and weights with packaging	12		
4.4 Handling with packaging	13		
4.5 Storage.	13		
4.6 Unpacking.	13		
4.7 Handling without packaging.	14		
4.8 Installation site.	14		
4.9 Installation mode	15		
4.10 Installation minimum distances.	15		
4.11 Positioning	15		
4.12 Hydraulic connections.	19		
4.13 Condensation drain preparation	20		
4.14 Filling the system.	22		
4.15 Electric connections	23		
5. Maintenance	26		
5.1 Preliminary warnings	26		
5.2 Routine maintenance	26		
5.3 Suggestions for energy saving.	29		
6. Troubleshooting	30		
6.1 Preliminary warnings	30		
6.2 Troubleshooting table.	30		

1. CODING

1.1 Product related coding

This instruction manual refers to the following product codes.





⚠ Check the correspondence with the technical rating plate on the product. See chapter "Identification" *p. 8*.

Aquarea Air - Floor Standing				
Code	Size	Connection side	Control Panel	Valves
P-FAL10SC-00E	10	Vertical left	-	-
P-FAL10DC-00E	10	Vertical right	-	-
P-FAL20SC-00E	20	Vertical left	-	-
P-FAL20DC-00E	20	Vertical right	-	-
P-FAL30SC-00E	30	Vertical left	-	-
P-FAL30DC-00E	30	Vertical right	-	-
P-FAL35SC-00E	35	Vertical left	-	-
P-FAL35DC-00E	35	Vertical right	-	-
P-FAL40SC-00E	40	Vertical left	-	-
P-FAL40DC-00E	40	Vertical right	-	-
P-FAL10SC-HLE	10	Vertical left	On-board panel	Auto 3 way
P-FAL10SC-RLE	10	Vertical left	Wall RC	Auto 3 way
P-FAL20SC-HLE	20	Vertical left	On-board panel	Auto 3 way
P-FAL20SC-RLE	20	Vertical left	Wall RC	Auto 3 way
P-FAL30SC-HLE	30	Vertical left	On-board panel	Auto 3 way
P-FAL30SC-RLE	30	Vertical left	Wall RC	Auto 3 way
P-FAL35SC-HLE	35	Vertical left	On-board panel	Auto 3 way
P-FAL35SC-RLE	35	Vertical left	Wall RC	Auto 3 way
P-FAL40SC-HLE	40	Vertical left	On-board panel	Auto 3 way
P-FAL40SC-RLE	40	Vertical left	Wall RC	Auto 3 way

2. GENERAL INFORMATION

2.1 About the manual





This manual was written to provide all the explanations for the correct management of the appliance.

-  This instruction manual forms an integral part of the device and therefore must be carefully preserved and must ALWAYS travel with it, even if you transfer the device to another owner or relocate it to other premises. If the manual gets damaged or lost, download a copy from the website.
-  Read this manual carefully before proceeding with any operation and follow the instructions in the individual chapters.
-  The Manufacturer accepts no liability for damages to persons or property caused by failure to follow the instructions in this manual.
-  This document is restricted in use to the terms of the law and may not be copied or transferred to third parties without the express authorisation of the Manufacturer.

2.1.1 Editorial pictograms

The pictograms in the next chapter provide the necessary information for correct and safe use of the machine in a rapid and unmistakable way.

Related to security

-  **High risk warning (bold text)**
 - The operation described above presents a risk of serious physical injury, fatality, major damage to the appliance and/or to the environment if not carried out in compliance with safety regulations.
-  Low risk warning (plain text)
 - The operation described above presents a risk of minor physical injury or minor damage to the appliance and/or to the environment if not carried out in compliance with safety regulations.
-  Prohibition (plain text)
 - Refers to prohibited actions.
-  **Important information (bold text)**
 - This indicates important information that must be taken into account during the operations.

In the texts

- ▶ procedures
- lists



In the control panels

- ▶ actions required
- Expected responses following an action.*

In the figures

1 The numbers indicate the individual components.

A The capital letters indicate component assemblies.

-  The white numbers in black marks indicate a series of actions to be carried out in sequence.
-  The black letter in white identifies an image when there are several images in the same figure.

2.1.2 Pictograms on the product

Symbols are used in some parts of the appliance:

Related to security



Read instruction manual

- Read the instructions carefully before performing any work on the appliance.



Instruction manual

- Read the information available in the technical documentation of the device.



Caution: electrical danger

- The concerned personnel is informed to the presence of electricity and the risk of suffering an electric shock.

2.1.3 Recipients

User

Non-expert person capable of operating the product in safe conditions for people, for the product itself and the environment, interpreting an elementary diagnostic of faults and abnormal operating conditions, carrying out simple adjustment, checking and maintenance operations.

Installer

Expert person qualified to position and connect (hydraulically, electrically, etc.) the unit to the plant; this person is responsible for handling and correct installation according to the instructions provided in this manual and the national standards currently in force.

Authorised Service Centre

Expert and qualified person authorised directly by the manufacturer to carry out all routine and supplementary maintenance operations, as well as every adjustment, check, repair and replacement of parts necessary during the life of the unit itself.

2.1.4 Manual organisation

The manual is divided into sections each dedicated to one or more target groups.

Coding

It addresses all recipients.

It contains the list of products and/or accessories referred to in the manual.

General information

It addresses all recipients.

It contains general information and important warnings that should be known before installing and using the appliance.

Product presentation

It addresses all recipients.

It contains the information to identify the product, its components, compatible accessories and destination of use.

Installation

It is addressed exclusively to the installer.

It contains specific warnings and all the information necessary for positioning, mounting and connecting the appliance.

Commissioning, maintenance and troubleshooting

They are addressed exclusively to the Authorised Service Centre.

It contains specific warnings useful information for the most common commissioning and routine maintenance.

Technical information

It addresses all recipients.

It contains detailed technical information about the appliance.

2.2 General warnings

- ⚠ Specific warnings are given in each chapter of the document and must be read before starting operations.
- ⚠ All personnel involved must be aware of the operations and dangers that may arise when beginning all unit installation operations.
- ⚠ Installation performed outside the warnings provided in this manual and use of the appliance outside the prescribed temperature limits will invalidate the warranty.
- ⚠ The installation and maintenance of climate control equipment can be dangerous due to its live electrical components inside the appliances. The installation, initial start-up and subsequent maintenance phases must be carried out exclusively by authorised and qualified personnel (see first start-up request form enclosed with the appliance).
- ⚠ Any contractual or extra-contractual liability for damage caused to persons, animals or property, due to installation adjustment and maintenance errors, or improper use, is excluded. All uses not expressly indicated in this manual are not permitted.
- ⚠ Only suitably qualified installers are authorised to install the device. After having completed installation, the installer will issue a declaration of conformity to the plant manager, as required by the applicable standards and the guidelines provided by contractor's instruction manual supplied with the device.
- ⚠ First start-up and repair or maintenance operations must be carried out by the Technical Assistance Centre or by qualified personnel following the provisions of this manual.
- ⚠ Do not modify or tamper with the appliance as this can lead to dangerous situations.
- ⚠ Use suitable personal protective clothing and equipment during installation and/or maintenance operations. The Manufacturer is not liable for the non-observance of the current safety and accident prevention regulations.
- ⚠ In the event of liquid or oil leaks, set the main switch of the plant to "OFF" and isolate water taps where applicable. Call the Authorised Service Centre or professionally qualified personnel as soon as possible and do not work on the appliance yourself.
- ⚠ In case of replacement of parts, use only original parts.
- ⚠ The Manufacturer reserves the right to make changes to its models at any time to improve its product, without prejudice to the essential characteristics described in this manual. The manufacturer is not obliged to add such modifications to machines previously manufactured, already delivered or under construction.
- ⚠ The unit can be used by children over the age of 8, and by people with reduced physical, sensory or mental capabilities, or with no experience or necessary knowledge, as long as they are monitored or after they have received instructions on the safe use of the unit and have understood the dangers involved. Children must not play with the appliance. The cleaning and maintenance that must be performed by the user should not be carried out by children without supervision.

2.3 Basic rules of security

Please keep in mind that the use of products powered by electricity and water call for operators to comply with certain essential safety rules:

- ⊖ It is forbidden to touch the device with wet or damp body parts.
- ⊖ It is forbidden to carry out any operation before disconnecting the appliance from the power supply by setting the plant main switch to "OFF".
- ⊖ It is forbidden to modify the safety or adjustment devices, or adjust without authorisation and indications of the Manufacturer.
- ⊖ It is forbidden to pull, unplug or twist the device's electric cables, even if it is disconnected from the mains.
- ⊖ It is forbidden to introduce objects and substances through the air inlet and outlet grilles.

- ⊖ It is forbidden to open the access doors of the device's internal parts without first having set main switch of the system to "OFF".
- ⊖ It is forbidden to incorrectly dispose of the packaging, or leave in the reach of children, which may become a source of danger.

2.4 Disposal

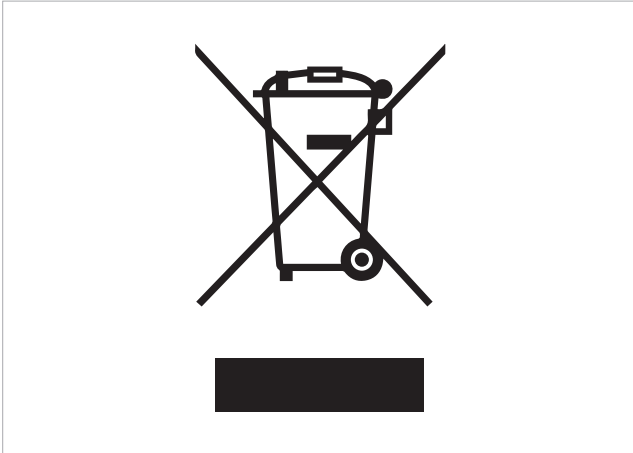

The symbol on the product or packaging indicates that the product must not be treated as normal household waste, but must be taken to the appropriate collection point for recycling of used electrical and electronic equipment and batteries.

Proper disposal of this product avoids harm to humans and the environment and promotes the reuse of valuable raw materials.

For more detailed information about the recycling of this product, contact your local authority, your household waste disposal service or the shop where you purchased the product.

Illegal disposal of the product by the user involves the application of the administrative sanctions provided for by the regulations in force.

This provision is valid in the EU Member States.

- ⚠ Avoid disassembling the unit yourself.
- ⚠ **Contact an Authorised Service Centre to disassemble the appliance.**

3. PRODUCT PRESENTATION

3.1 Identification

The appliance can be identified by the rating plate:

Technical rating plate

⚠ Tampering with, removal of, or lack of identification plates will not allow for the safe identification of the product by its serial number and therefore invalidates the warranty.

1. Technical rating plate

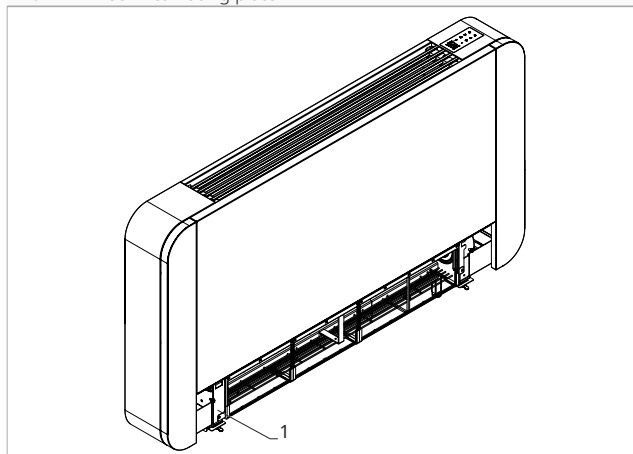

3.2 Destination of use

These appliances have been designed for conditioning and/or heating rooms and they must be destined solely for

this purpose, in accordance with their performance characteristics.

⊖ It is forbidden to use the device other than as indicated.

3.3 Description of the appliance

The fan coils are designed for indoor installation, with an exposed metal cabinet.

The range can be divided into configurations:

- vertical installation with connections on the right
- vertical installation with connections on the left
- horizontal installation with connections on the right
- horizontal installation with connections on the left

⚠ For horizontal installation of the unit, the condensate collection kit is required. See section "Compatible accessories" *p. 10*.

Suitable for 2-pipe installation.

The device are made in five different performance levels and size:

- 10
- 20
- 30
- 35
- 40





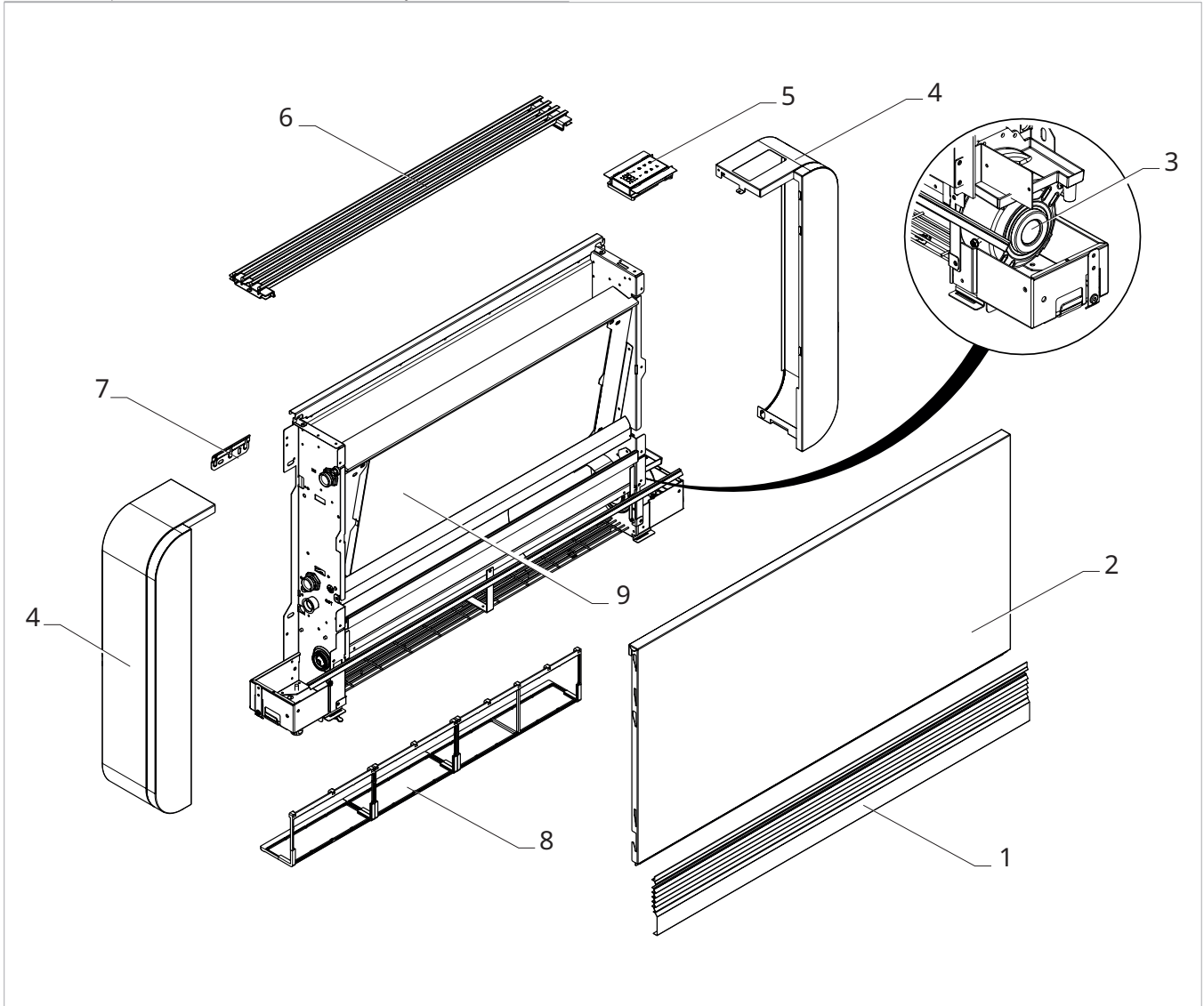

3.4 Components

- | | | | |
|----|--|----|------------------------|
| 1. | Front grille | 6. | Upper grille |
| 2. | Cover cabinet | 7. | Wall mounting brackets |
| 3. | Fan motor | 8. | Air filter |
| 4. | Side panels | 9. | Heat exchanger |
| 5. | Preparation for on-board control (accessory) | | |



3.5 Compatible accessories

⚠ Check the matching products column for a match with the size purchased.

	Accessory description	Combinable products	Code
Controls on the appliance			
	On-board control, with continuously modulating thermostat.	All	PCZ-ECA844
	On-board control, with continuously modulating thermostat, with integrated Wi-Fi module.	All	PCZ-EWA844
Wall-mounted control panels			
PCB			
	Electronic board on board unit with continuous modulation. For connection to wall-mounted control.	All	PCZ-ESE845
Control panels			
	LED electronic control panel with touch interface, wall mounted complete with thermostat and room temperature and relative humidity probe. Cable connection. White colour	All	PCZ-EEB749
	LED electronic control panel with touch interface, wall-mounted complete with thermostat and room temperature and relative humidity probe with integrated Wi-Fi module. Cable connection. White colour	All	PCZ-EFB749
Standard wall mounted controls			
PCB			
	On-board electronic printed circuit board for control from systems with 0-10 V analogue output.	All	PCZ-B10842
Installation accessories			
Condensate collection tray			
	Kit bacinella orizzontale per posizionamento a soffitto dell'unità. Dimensioni (lxhxp) 481x365x40 mm	10	PCZ-GB0520
	Kit bacinella orizzontale per posizionamento a soffitto dell'unità. Dimensioni (lxhxp) 681x365x40 mm	20	PCZ-GB0521
	Kit bacinella orizzontale per posizionamento a soffitto dell'unità. Dimensioni (lxhxp) 881x365x40 mm	30	PCZ-GB0522
	Kit bacinella orizzontale per posizionamento a soffitto dell'unità. Dimensioni (lxhxp) 1081x365x40 mm	35	PCZ-GB0523
	Kit bacinella orizzontale per posizionamento a soffitto dell'unità. Dimensioni (lxhxp) 1281x365x40 mm	40	PCZ-GB0524
Feet for floor fixing			
	Feet for anchoring the unit to the floor	All	PCZ-LC0606
Aesthetic feet			
	Feet for covering floor pipes, h=80 mm.	All	PCZ-LC0158
Accessories supplied separately			
Modules			
	Electronic board for external terminal control (e.g. radiant panel or radiator valves). For connection to wall control units PCZ-EEB749 / PCZ-EFB749.	All	PCZ-EG1028
Valves			

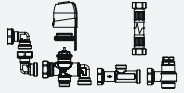
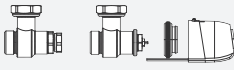
	Accessory description	Combinable products	Code
HYDRAULIC KIT			
	3-way valve unit with thermoelectric motor	All	PCZ-V30720
	2-way valve unit with thermoelectric motor	All	PCZ-V20139

4. INSTALLATION

4.1 Preliminary warnings

- ⚠ **This section is dedicated to the Installer. The features of the installer are described in the "Recipients" p. 5 chapter.**
- ⚠ **For detailed information on the products, refer to chapter "Technical information" p. 31.**
- ⚠ The installation must be carried out by the installer in accordance with national installation regulations. There is a risk of water leakage, electric shock or fire if the installation is not performed correctly.

- ⚠ During the installation, it is necessary to observe the precautions mentioned in this manual, and on the labels placed inside the equipment, as well as to adopt any precaution suggested by common sense and by the Safety Regulations in force in the place of installation.
- ⚠ Be sure to use the supplied or specified installation parts. Use of other parts may cause the unit to come loose, leak water, or cause electrical shock, or fire.
- ⚠ The Manufacturer accepts no liability for damage caused to animals or property due to failure to apply the indicated rules which may cause malfunction of appliances.

4.2 Reception

4.2.1 Preliminary warnings

- ⚠ On receipt check for any damage and, if any is found, accept the goods with reservation, and keep photographic evidence of any damage found
- ⚠ In the event of damage, notify the shipper within 3 days of receipt of any damage by registered mail with return receipt, submitting photographic evidence. Similar information should be sent by email to the manufacturer (jurisdiction will be at the Court Trento for any dispute).
- ⚠ No notice of damage will be accepted after 3 days from delivery.

- ⚠ Unpack and check the contents of individual components against the packing list.

4.2.2 Package description

The packaging is made of suitable material and carried out by experienced personnel. All units are checked and tested and are delivered complete and in perfect condition. The appliance is shipped in standard packaging consisting of a cardboard sleeve and a set of expanded polystyrene protectors.

4.3 Dimensions and weights with packaging

L	Total width
H	Total height
P	Total depth

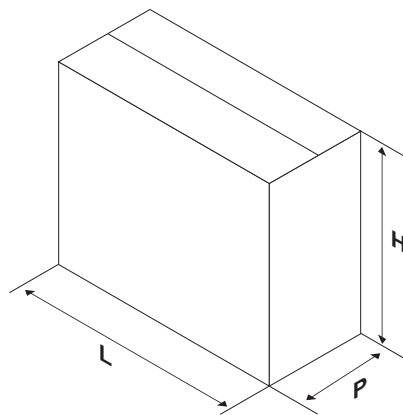

Models	m.u.	10	20	30	35	40
Dimensions and weight for shipping						
Width	mm	735	935	1135	1335	1535
Height	mm	579	579	579	579	579
Total depth	mm	129	129	129	129	129
Weight	kg	18,0	20,0	23,0	26,0	29,0

4.4 Handling with packaging

4.4.1 Preliminary warnings

- ⚠ The appliance must be handled only by qualified personnel, adequately equipped and with equipment suitable for the weight and dimensions of the appliance.
- ⚠ Stay clear of the area below and around it when the load is lifted off the ground.
- ⚠ Avoid dangerous situations when using a hoist to lift the appliance.

4.4.2 Movement methods

Boxes can either be carried singularly by hand by two operators or loaded on a forklift truck evenly stacked.

- ⚠ Check the indications on the packaging for the number of packages that may be stacked together.
- ⚠ In manual operation it is compulsory to always respect the maximum weight per person provided for by the national laws and standards.

- ⚠ Use the handles provided on the packaging.

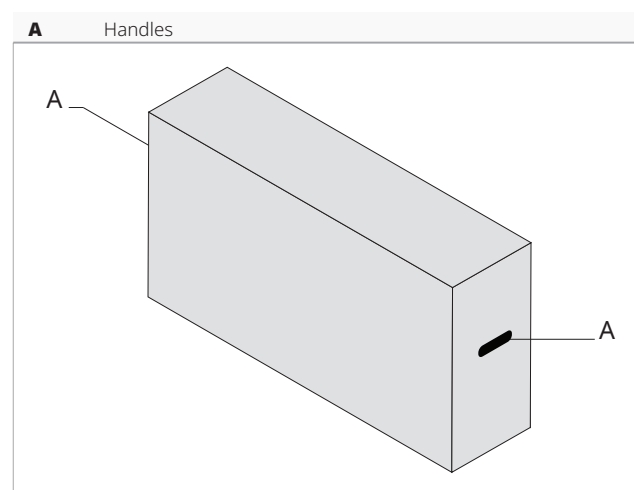

4.5 Storage

4.5.1 Preliminary warnings

- ⚠ Store in accordance with the applicable national regulations.
- ⚠ Store the box in a closed environment protected from atmospheric agents and isolate it from the floor using planks or pallets.
- ⚠ Store in a clean and dry place.
- ⚠ Place the appliance in an vertical position.

4.6 Unpacking

4.6.1 Preliminary warnings

- ⚠ Check that no components were damaged during transport.
- ⚠ Dispose of the packaging components following the applicable waste disposal regulations. Check for disposal arrangements with your municipality.
- ⚠ Handle with care.
- ⊖ The packing material (cardboard, staples, plastic bags, etc.) must not be dispersed or abandoned in the surrounding environment and must be kept out of the reach of children, as it poses a risk of danger.

4.6.2 Remove the package

1. Protective elements

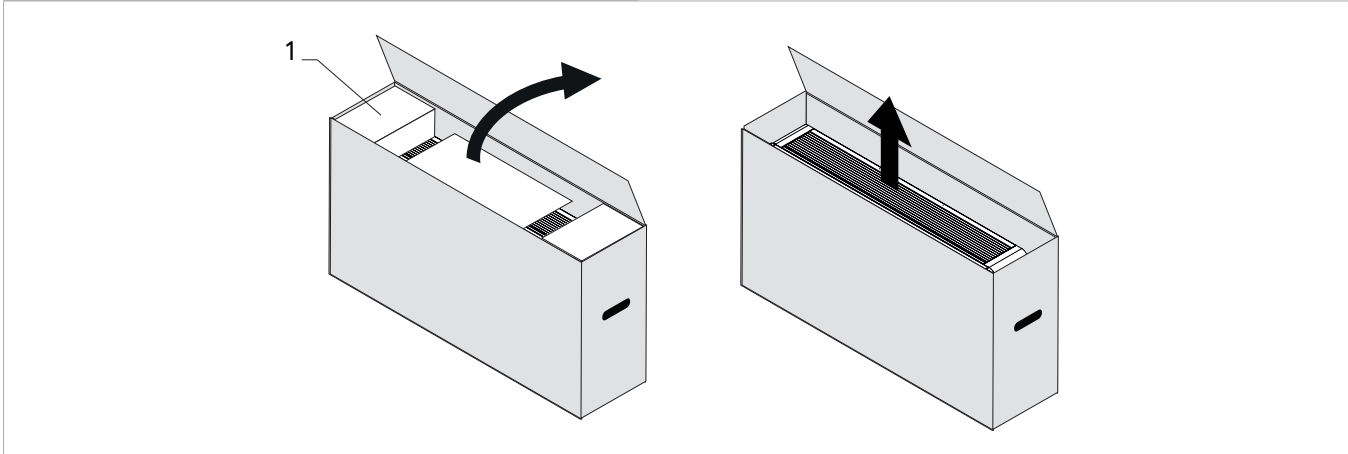

Remove the packing:

- ▶ open the cardboard packaging
- ▶ remove the metal brackets

- ▶ remove protective elements
- ▶ extract the supplied material
- ▶ remove the appliance from the box

Accompanying material

Inside the packaging are:

- 1 instruction sheet for downloading the manuals
- 1 label for scanning the QR Code
- 1 installation template

- 2 wall mounting brackets
- 2 safety clamps
- grille fixing screws

⚠ Check the presence of the individual components.

4.7 Handling without packaging

4.7.1 Preliminary warnings

⚠ The appliance must be handled only by qualified personnel, adequately equipped and with equipment suitable for the weight and dimensions of the appliance.

4.7.2 Movement methods

⚠ The unit can be moved manually for short distances. In this case it is necessary to check carefully that the weight of the unit does not exceed the regulations in relation to the number of people used.

4.8 Installation site

Position of device must be established by the system designer or other qualified professional and must take into account both technical requirements and any local laws in force.

4.8.1 Preliminary warnings

- ⚠ Avoid installing the unit near:
- obstacles or barriers that cause recirculation of the exhaust air
 - narrow places where the sound level of the appliance can be enhanced by reverberations or resonances
 - environments with the presence of flammable or explosive gases
 - very humid environments (laundries, greenhouses, etc.)
 - environments with aggressive atmospheres
 - solar radiation and proximity to heat sources
 - rooms subject to high frequencies

⚠ Avoid placing the unit within 1 metre of radio and video equipment.

⚠ Do not install over heat sources.

⚠ Make sure that:

- the installation site of the unit must be chosen with the utmost care to guarantee adequate protection from shocks and consequent damage
- the supporting structure is able to support the weight of the appliance
- the supporting structure section does not feature building supporting elements, pipes or power lines
- the supporting surface is perfectly levelled
- there are no obstacles to the free circulation of air
- the appliance must be installed in a position where it can be easily serviced
- the safety distances between the units and other appliances or structures are scrupulously respected so that the air entering and leaving the fans is free to circulate

- ⚠ If the appliance is installed incompletely or on an inappropriate base, it could cause damage to persons or property if it should detach from its base.
- ⚠ The unit should not be installed in a position where the air flow is aimed directly at the people nearby.

- ⚠ Provide the following:
 - a nearby drain for the outflow of condensate
 - a compliant power supply nearby
 - fixing elements suitable for the type of support

4.9 Installation mode

- ⚠ For ideal installation and performance levels, carefully follow the instructions in the manual.
- ⚠ Failure to do so may cause system malfunctions and automatically voids the warranty, and relieves the manufacturer of any harm caused to person, animals or property.

4.10 Installation minimum distances

The clearance zones for the installation and maintenance of the appliance are shown in the figure. Established spaces are necessary to avoid barriers to airflow and allow for normal cleaning and maintenance.

- ⚠ Make sure that there is sufficient space to allow the panels to be removed for routine and supplementary maintenance operations.

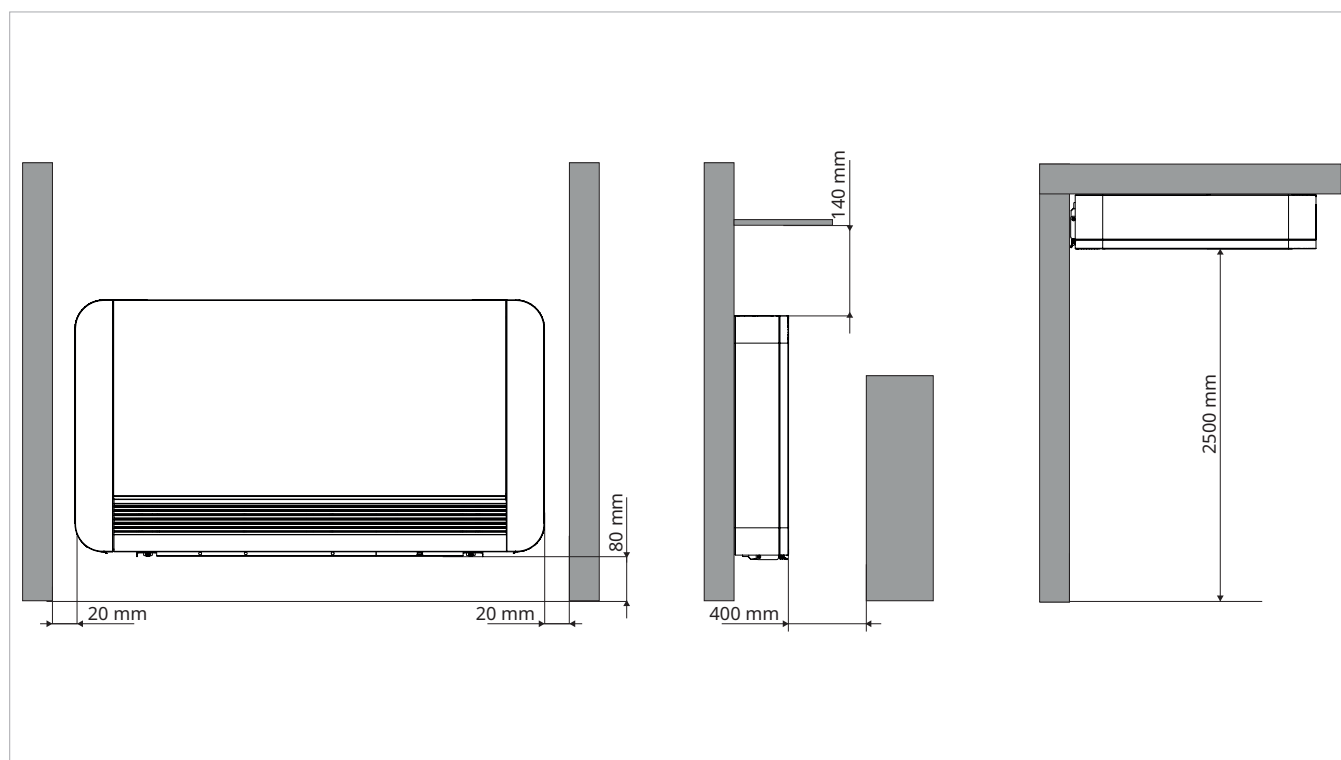

4.11 Positioning

- ⓘ The assembly steps described below and their drawings refer to a version of the machine with connections on the left side.

4.11.1 Preliminary warnings

- ⚠ The unit requires two or more people to position the unit.
- ⚠ Depending on the version you are installing, the appliance can be installed horizontally or vertically. Check the nameplate with the list in chapter "Product related coding" *p. 4*.
- ⚠ Ensure that:
 - the wall supports the weight of the appliance

- the section of the wall does not contain piping or electrical lines
- the functionality of load-bearing elements is not compromised

4.11.2 Device preparation

Before proceeding with the installation, it is necessary to remove some elements from the appliance.

⚠ The images refer to a version of the appliance with the connection on the left. If the appliance has the connection on the right side, the operation must be adapted to the position of the attacks.

1. Removal of upper grille

1. Fixing screws

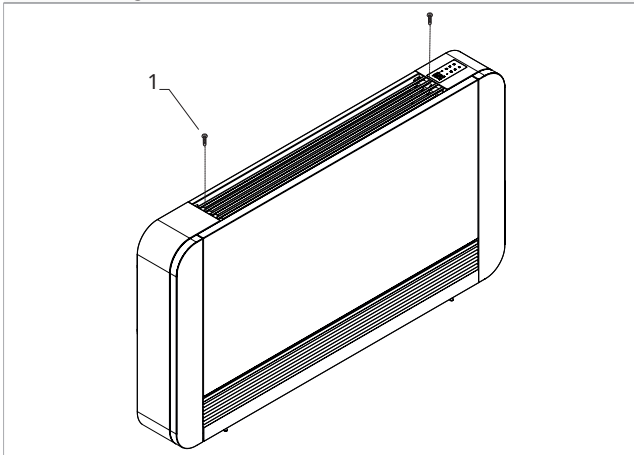

- ▶ remove the fixing screws

1. Upper grille

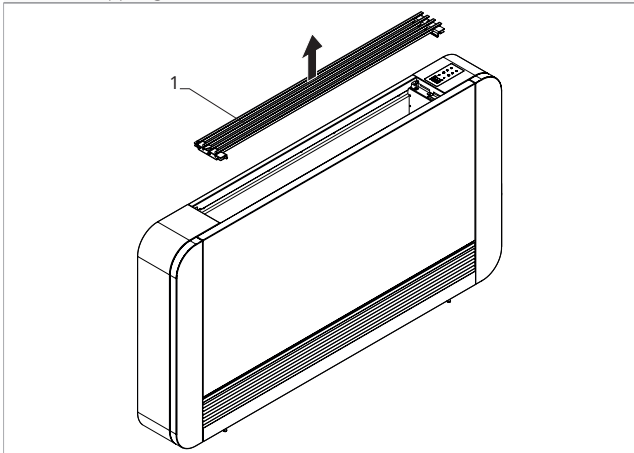

- ▶ lift and remove the upper grille

2. Front grille removal

1. Front grille

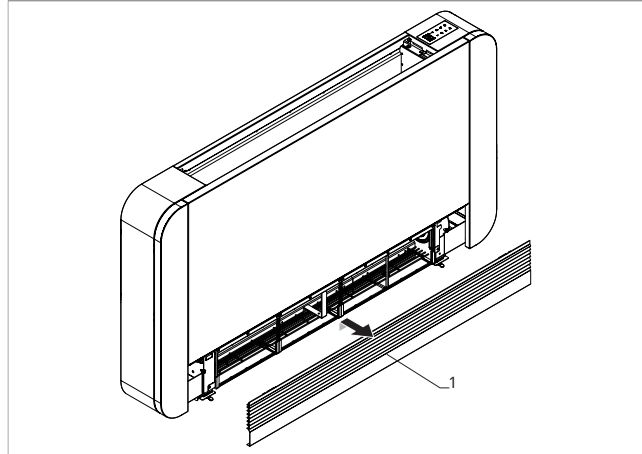

- ▶ lift the front grille
- ▶ pull and remove the grille

3. Side panel removal

1. Fixing screws

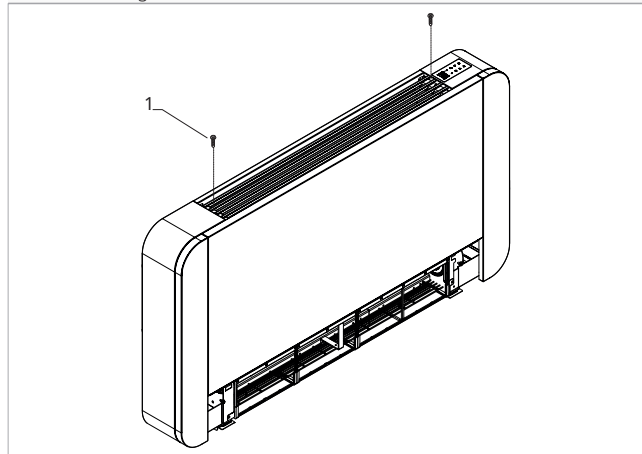

- ▶ lift the screw covers on the top of the appliance
- ▶ remove the fixing screws

1. Side panels

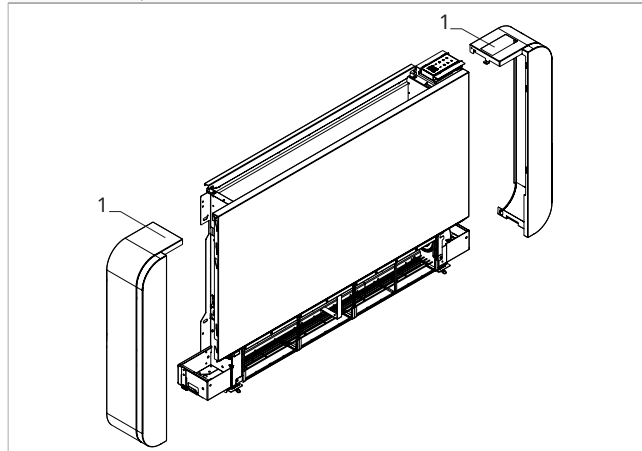

- ▶ slightly move the side panel outwards
- ▶ lift and remove the side

4.11.3 Positioning for vertical configurations

⚠ The units are supplied with a paper template for marking the holes necessary for installation.

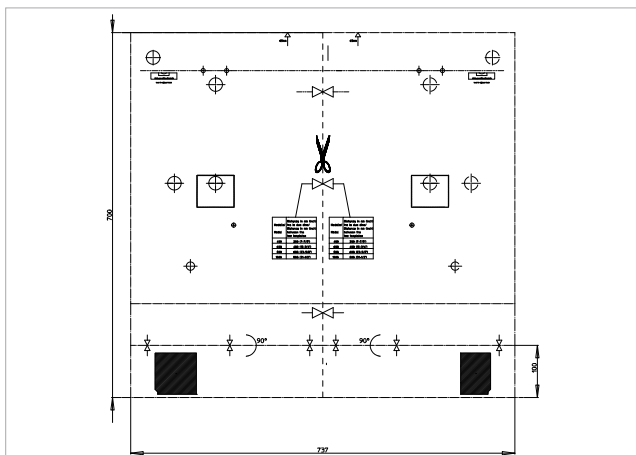

- ▶ use the paper template supplied with the device
- ▶ trace the position of the fixing brackets
- ▶ drill holes in the wall

⚠ Hold the template in the correct position with tape.

⚠ The template is unique for all sizes. For some sizes it is necessary to cut the template following the instructions within it.

- | | |
|----|-----------------|
| 1. | Plugs |
| 2. | Fixing brackets |

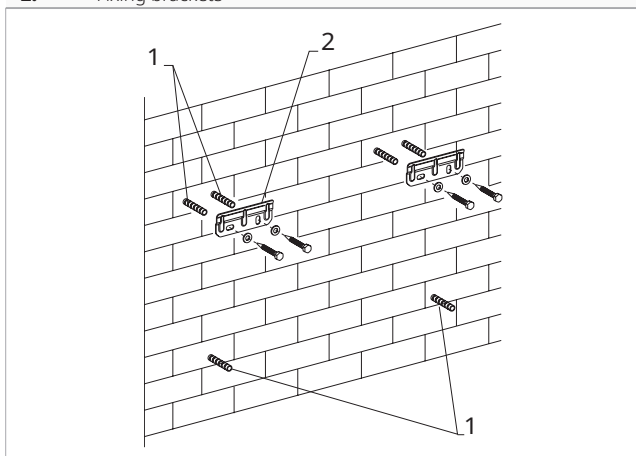

- ▶ insert the expansion plugs
- ▶ position the support brackets
- ▶ partially secure the screws

⚠ Do not fully secure the screws so that you can adjust the position of the appliance.

⚠ Use expansion plugs suitable for the chosen supporting structure.

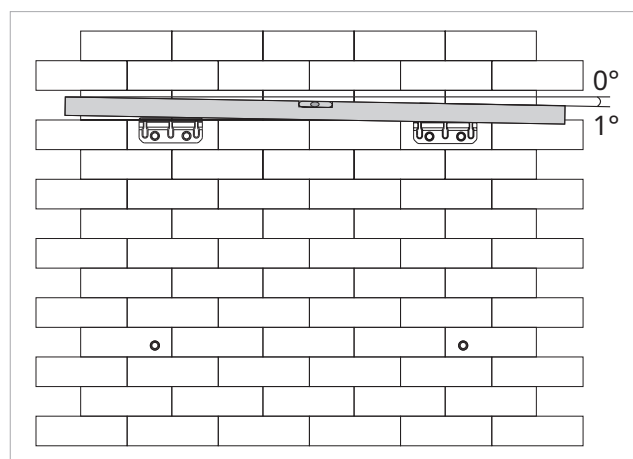

- ▶ use a level
- ▶ check the inclination towards the attachment side
- ▶ secure the screws

⚠ A maximum inclination of 1° towards the right side of the appliance is allowed to facilitate the drainage of condensate.

- | | |
|----|-----------------|
| 1. | Fixing brackets |
| 2. | Unit |
| 3. | Fixing screws |

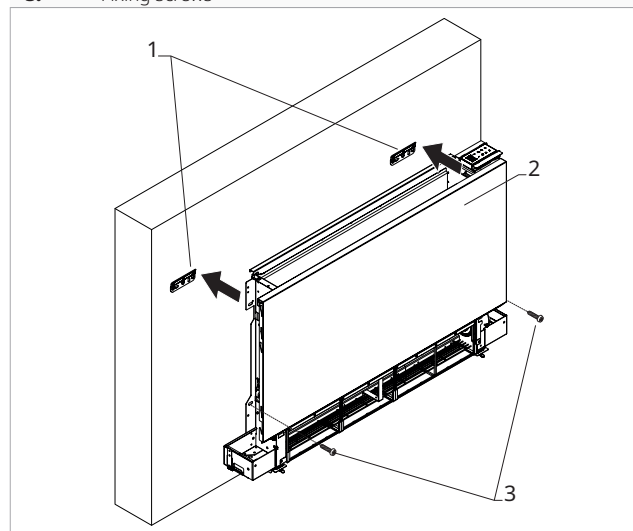

- ▶ Attach the unit to the fixing brackets
- ▶ check right attachment to the fixing brackets
- ▶ Secure the unit with the fixing screws
- ▶ reassemble the unit

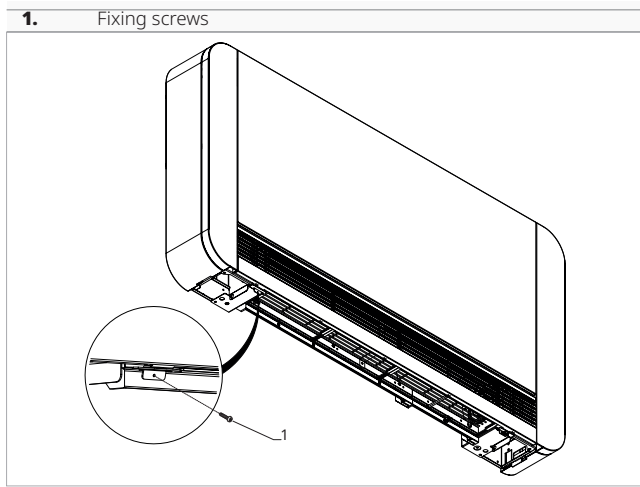

► insert the screws into the grille fin holes and secure

⚠ To prevent accidental removal of the grille, thus preventing the proper operation of the fan coil unit, two screws are provided for fixing the front grille.

4.11.4 Positioning for horizontal configurations

⚠ The units are supplied with a paper template for marking the holes necessary for installation.

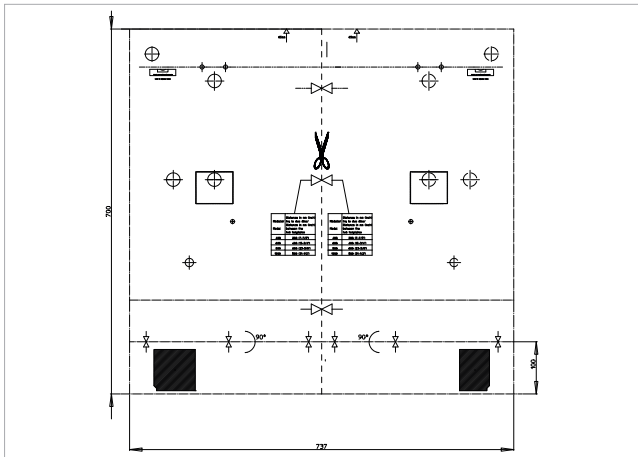

- use the paper template supplied with the device
- trace the position of the fixing brackets
- drill holes in the wall

⚠ Hold the template in the correct position with tape.

⚠ The template is unique for all sizes. For some sizes it is necessary to cut the template following the instructions within it.

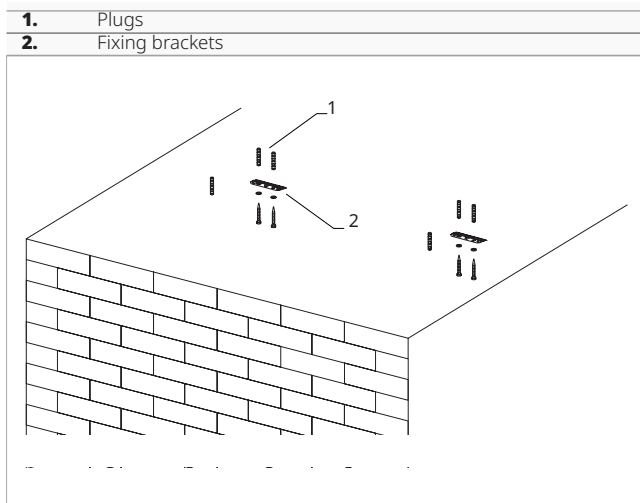

- insert the expansion plugs
- position the support brackets

⚠ Use expansion dowels suitable for the chosen support wall

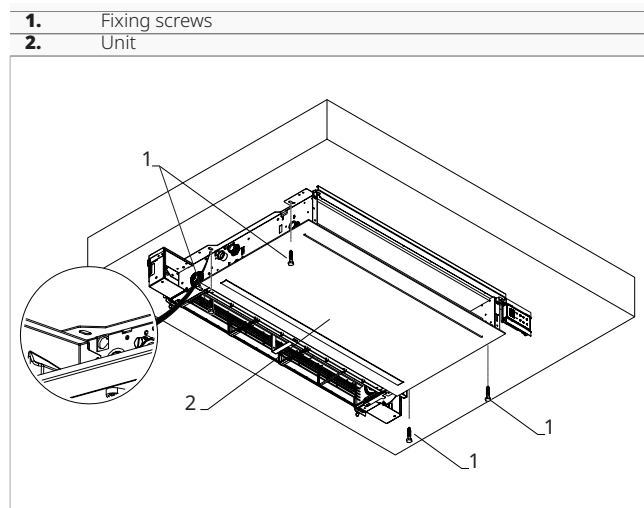

- use fixing screws
- lock the unit

⚠ Do not fully secure the screws so that you can adjust the position of the appliance.

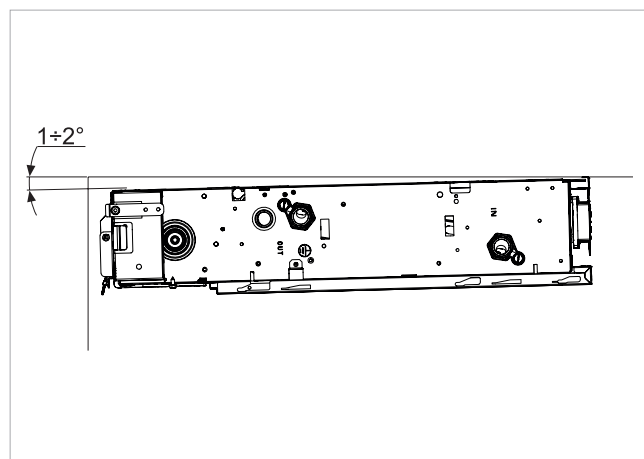

► use a level

- ▶ check the inclination towards the attachment side
- ▶ secure the screws

⚠ A maximum inclination of $1\pm 2^\circ$ toward the condensate drain connection is allowed to facilitate the drainage of condensate.

- | | |
|----|--------------|
| 1. | Front grille |
| 2. | Clamp |
| 3. | Screws |

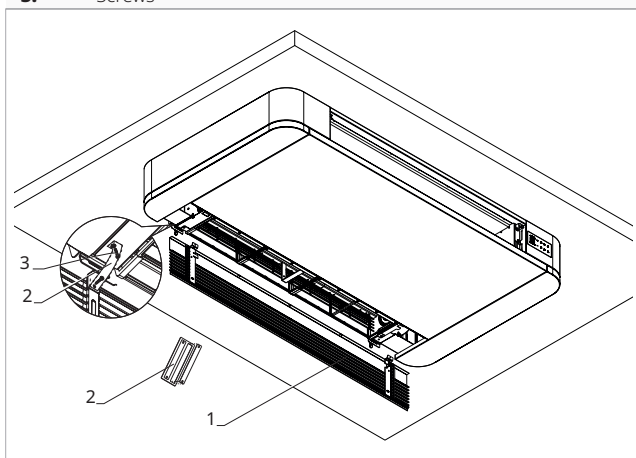

- ▶ separate the 2 clamps
- ▶ open the front grille
- ▶ unscrew the spring fixing screws
- ▶ fix one end of the clamps with the screws
- ▶ fix the other end of the clamps to the front grille using the fixing screws
- ▶ close the grille

⚠ In case of horizontal positioning of the appliance, to ensure the safety of maintenance operations, the 2 safety clamps (supplied with the unit) must be mounted.

4.12 Hydraulic connections

4.12.1 Preliminary warnings

- ⚠ The engineer is responsible for choosing the right water lines and their size, in accordance with good installation practices and the applicable law.
- ⚠ The hydraulic system is made by the installer and must be carried out with reference to the diagrams in this manual or on the website.

⚠ The hydraulic pipes connecting to the appliance must be suitably sized for the actual water flow required by the system in operation.

⚠ Undersized pipelines lead to poor system operation and/or a loss of thermal and cooling performance.

4.12.2 Position and dimensions

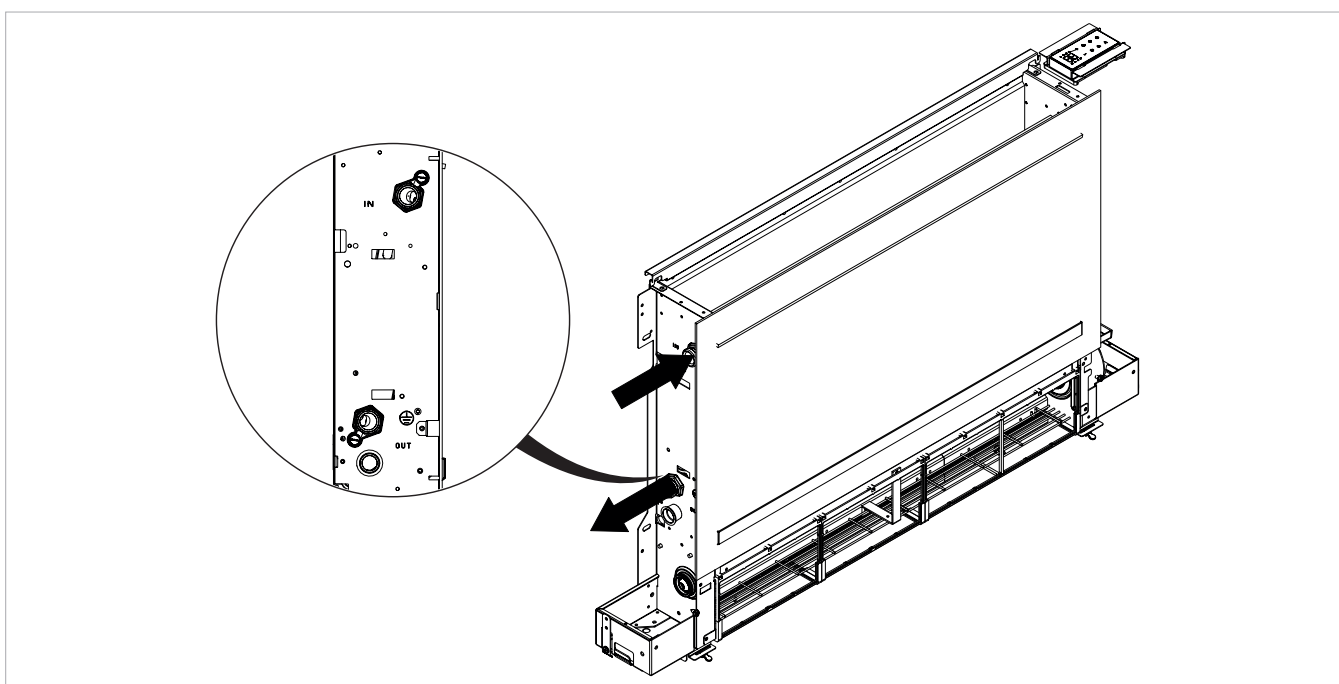

Models	m.u.	10	20	30	35	40
Pipeline diameter	mm	14	14	16	18	20

⚠ For dimensional information, refer to chapter "Technical information" p. 31.

4.12.3 System connection

To make the connections:

- ▶ hydraulic lines positioning
- ▶ tighten the connections
- ▶ check for leaks
- ▶ coat the connections with insulating material

⚠ The hydraulic lines and fittings must be thermally insulated.

⚠ Avoid partial insulation of the pipes.

⚠ Avoid over-tightening the tape to avoid damaging the insulation.

⚠ Carefully check that the insulation is tight, in order to prevent the making and dripping of condensate.

4.12.4 Shut-off valves

As standard, the unit is supplied without shut-off valves

⚠ For valve installation, refer to the relevant instruction sheet provided with the valve kit.

4.13 Condensation drain preparation

4.13.1 Preliminary warnings

⚠ This appliance is complete with a tray for collecting the condensation produced during operation, which must be channelled to a suitable place for drainage.

⚠ Use the installation template to correctly position the condensate drain pipe flush with the wall. See chapter "Installation template" p. 33.

⚠ The hole for the condensation pipe must always slope towards the outside.

⚠ When connecting the condensate drain hose take great care to avoid crushing the rubber hoses.

⚠ In case the fancoil unit is used for heating only, condensate drainage is not necessary. In this case close the drain.

If using a jug for collecting the condensation:

⚠ Avoid the hermetic closure of the container.

⚠ Prevent the end of the drainage tube from falling below the water level.

If draining into the sewage system:

⚠ Make a siphon to prevent bad smells returning up the pipe towards the room. The curve of the siphon must be lower than the condensation collection pan.

⚠ The syphon must feature a plug in its lower part or must otherwise allow for quick disassembly for cleaning purposes.

⚠ Install a pump if the drain pipe is higher than lower level of the collection pan.

⚠ For vertical installations, the pump must be installed under the side drain pan.

⚠ For horizontal installations, the pump should be installed according to specific requirements.

If using an open drain:

⚠ Drain the condensate liquid flow directly onto a gutter or into a "grey water" drain

⚠ If the condensation is not collected, it will be deposited on the support surface. The water could freeze if the outdoor temperatures are below zero, thus creating a hazard. In this case, appropriate barriers should be installed in order to prevent people from approaching the area.

4.13.2 Condensate drain dimensions

Models	m.u.	10	20	30	35	40
Condensate drain connection	mm	14	14	14	14	14

4.13.3 Connection for vertical installations

1. Drop-break extension
2. Condensate drain connection
3. Liquid drain pipe

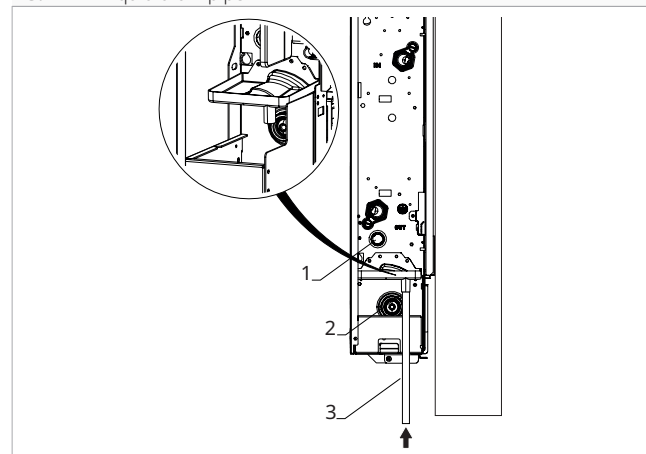

- ▶ connect the condensate drain pipe to the condensate drain connection
- ▶ direct the liquid drain pipe towards a suitable location for drainage
- ▶ keep a minimum slope of 3% towards the drain location
- ▶ insulate fitting points

⚠ Check that the drop-break extension is present and properly installed.

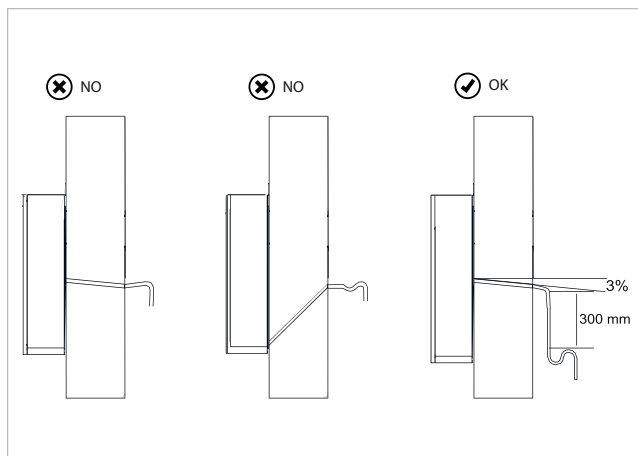

- ⚠ Pay attention to the angle of the condensate drain pipe.
- ⚠ Use plastic drainage pipes.
- ⚠ Avoid pipes made of metallic material.
- ⚠ Make sure all joints are sealed to prevent leakage of water.
- ⚠ Condensate drainage pipes must be insulated for both indoor and outdoor sections of the house to avoid condensation on the surface and/or freezing problems.
- ⚠ When mounting the pump, for vertical installations, the pump should be mounted under the side drain pan.

4.13.4 Connection for horizontal installations

1. Condensate drain tray
2. Condensate drain connection
3. Adapter connection
4. Copper pipe

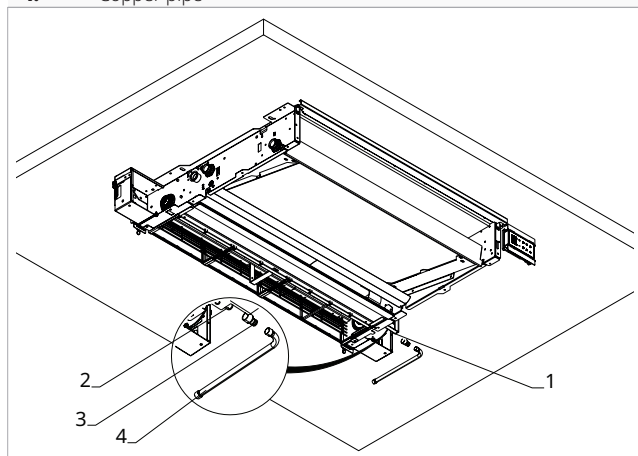

- ▶ Connect the adapter fitting to the condensate drain connection
- ▶ Connect the copper pipe to the adapter fitting

1. Liquid drain pipe

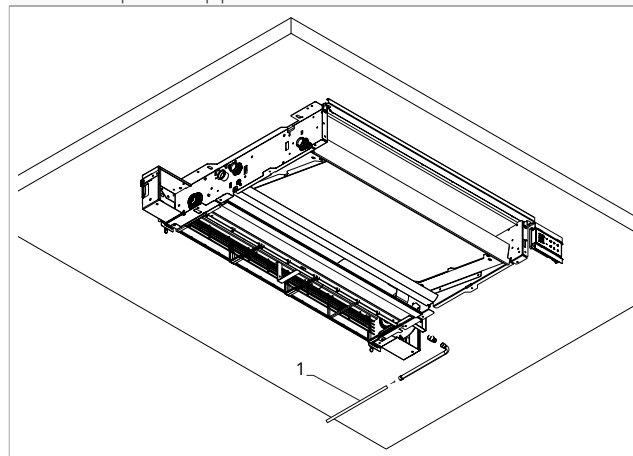

- ▶ connect the condensate drain pipe to the copper pipe
 - ▶ direct the liquid drain pipe towards a suitable location for drainage
 - ▶ keep a minimum slope of 3% towards the drain location
 - ▶ insulate fitting points
- ⚠ Condensate drainage pipes must be insulated for both indoor and outdoor sections of the property to avoid condensation on the surface and/or freezing problems. The insulation must be fitted until the condensate drain pipe is plugged into the connection provided on the unit.
- ⚠ Avoid counter-slope sections.

1. Unit

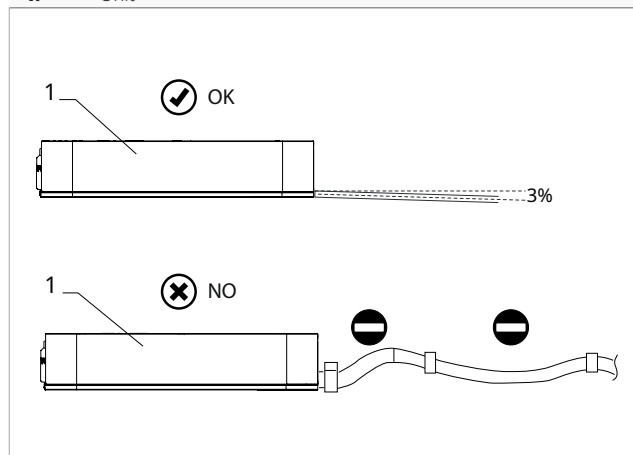

4.13.5 Check

Make sure that:

- the unit is installed perfectly level, or with a slight slope in the direction of condensate drainage
- The condensate drain pipe has been properly insulated to the inlet of the unit, so as to prevent condensate drips outside the drip pan itself

After the installation is completed:

- ▶ pour water very slowly into the condensate drain pan
- ▶ check for correct condensate drainage

4.14 Filling the system

⚠ When starting the system, make sure the lockshield on the hydraulic unit is open.

⚠ If there is a power failure and the thermostatic head has been powered before, it will be necessary to use the appropriate cap to press the valve shutter to open it.

- A Vertical installation
- B Horizontal installation

- 1. Coil vent

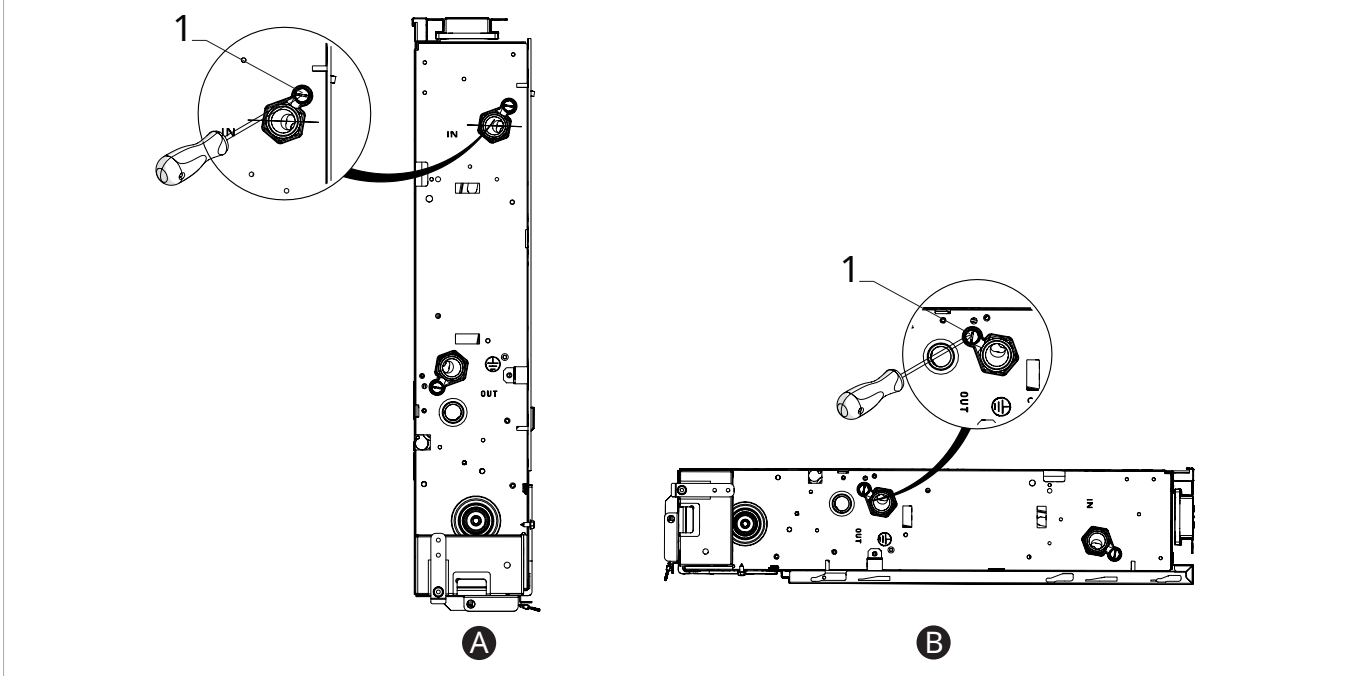

To fill the system:

- ▶ open the vent valves
- ▶ open all the system's shut-off devices
- ▶ slowly introduce the water supply

⚠ For vertically installed models, using a screwdriver, open the battery vent located higher up.

⚠ For models installed in a horizontal position, use a screwdriver on the vent of the battery located at the highest point.

When water begins to leak out of the vent valves:

- ▶ close the vent valves
- ▶ complete system filling
- ▶ verify that you have reached the nominal pressure for the system
- ▶ isolate the water supply
- ▶ check the tightness of the gaskets

⚠ It is recommended to repeat this operation after the device has been running for a few hours.

⚠ Regularly check the system's pressure.

⚠ Check the hydraulic seal of the gaskets.

- 1. Thermostatic head
- 2. Valve body
- 3. red plastic tool

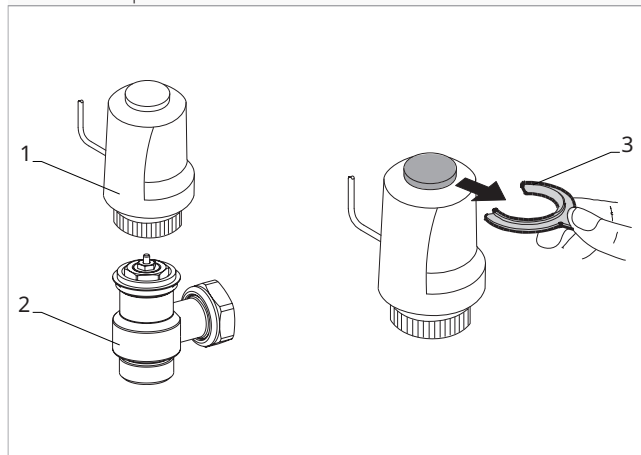

4.14.1 Mounting the thermostatic head

To mount the thermostatic head:

- ▶ tighten the head to the valve body

To facilitate the system mounting, filling and venting operations, even without electric power, the thermostatic head is supplied with a tool that keeps it open.

⚠ Remove the tool from the thermostatic head before starting the system.

4.15 Electric connections

The device leaves the factory fully wired and needs only the connection to the power supply, to any controls and accessories.

4.15.1 Preliminary warnings

- ⚠ All operations of an electrical nature must be carried out by qualified personnel having the necessary training, who understands the legal requirements, and is informed about the risks related to such operations.
- ⚠ All connections must be made following the regulations in force in the country of installation.
- ⚠ Before carrying out any work, isolate and lock off the main supply, posting a notice indicating that work is being carried out.
- ⚠ The unit must only be powered after all plumbing and electrical work has been completed.
- ⚠ References:
 - refer to the wiring diagrams in this manual for the electrical connections, especially the part concerning the power supply terminal block

Make sure that:

- the characteristics of the electric network are adapted to the absorption of the apparatus, considering also any other devices in parallel operation
- the power supply voltage and system frequency match to the values indicated on the device's plate data
- the cables must be appropriate for the type of installation in accordance with the applicable IEC standards
- the power supply is provided with protection against overload and/or short-circuit
- the disconnection device is located in an easily accessible place in order to be able to intervene in the event of an emergency

It is required:

- provide a suitable earthing connection
 - It is understood that all units are single phase
 - provide an all-pole switch with a contact opening distance of 3 mm or more that allows complete disconnection under overvoltage category III conditions
 - Install a residual-current circuit breaking device. Failure to install this device may result in electric shock.
- ⚠ Use a dedicated power supply circuit. Never use a power supply to which another appliance is also connected because of the risk of overheating, electric shock or fire.
 - ⚠ The device is equipped with suppression filter as laid down by the applicable laws and standards. Use selective circuit breakers to compensate for the micro-dispersion on the earthing of this device.
 - ⚠ For the electrical connection, use a cable that is long enough to cover the entire distance without any connection. Do not use extension cables. Do not apply other loads on the power supply.
 - ⚠ After connecting the interconnection and power cables, make sure that the cables are routed so that they do not apply excessive forces on the covers or electrical panels. Incomplete connection of the covers may result in overheating of the terminals, electric shock or fire.
 - ⊖ It is forbidden the use of gas and water pipes for earthing the appliance.
 - ⚠ If you need to replace the power cable, contact only qualified staff and in compliance with the applicable national laws.
 - ⚠ The Manufacturer is not liable for any damage caused by the lack of earthing or failure to comply with the specifications in the respective diagrams.
 - ⚠ Isolate and lock off the main supply, posting a notice indicating that work is being carried out, before making any electrical connections and performing maintenance on the equipment.

4.15.2 Power line dimensioning

For the size of the power supply cable and safety devices, use the following table.

Models	m.u.	10	20	30	35	40
Power conductor (phase+neutral)	mm ²	1,5	1,5	1,5	1,5	1,5
Protective conductor section on ground	mm ²	1,5	1,5	1,5	1,5	1,5
Circuit breaker	mm ²	2	2	2	2	2

4.15.3 Access to the terminal block

- | | |
|--------------------------------|------------------------------|
| 1. Fixing screws | 3. Terminal block for wiring |
| 2. Cover of the electrical box | |

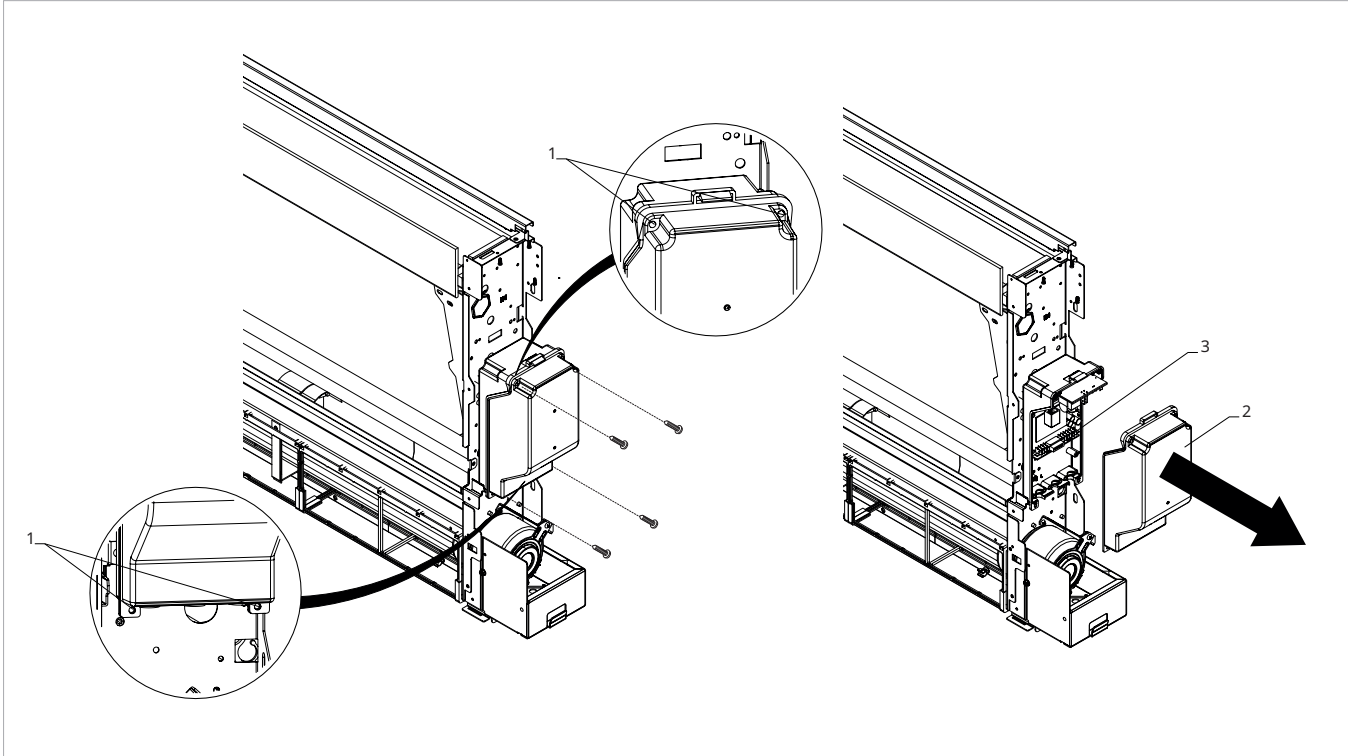

⚠ Before carrying out any work, isolate and lock off the main supply, posting a notice indicating that work is being carried out.

⚠ Access to the electrical panel is only permitted to qualified personnel.

To access:

- ▶ remove aesthetic side panels
- ▶ disconnect the on-board display connector (if present)

To access the connections:

- ▶ unscrew the fixing screws of the electric box
- ▶ remove the lid from the junction box

⚠ Refer to the information in the wiring diagram of the unit you are installing.

⚠ The electrical connection can be made by a cable recessed into the wall as indicated on the installation template (connection recommended for installation of the device at the top of the wall).

⚠ It is necessary to check that the power supply is provided with appropriate protection against electric shorts and/or overloads

⚠ Refer to the control installation manual to make the connection of the control.

4.15.4 Power supply connection

⚠ The appliance is supplied as standard without any wall-mounted control panel.

Accompanying material

Accompanying the unit, contained in a bag placed on the cover of the electrical box, are:

- 1 terminal for power supply connection (L-N)
- cable gland
- screws

Connection

- | |
|------------------------------|
| 1. Terminal block for wiring |
| 2. Power supply cables |
| 3. Quick-connect terminal |
| 4. Earth connection |

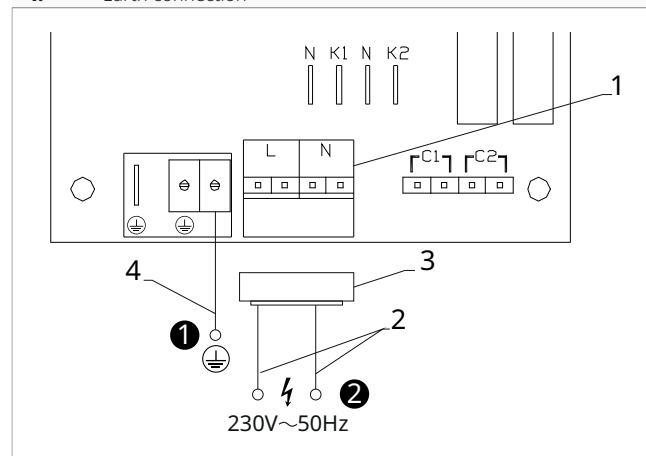

To make the connections:

- ▶ use the supplied quick terminal
- ▶ connect phase and neutral (L-N) to the quick terminal
- ▶ connect the quick-connect terminal to the terminal block

- ▶ connect the ground wire (PE) to the terminal provided on the electrical panel

⚠ Refer to the control installation manual to make the connection of the control.

1. Cable gland

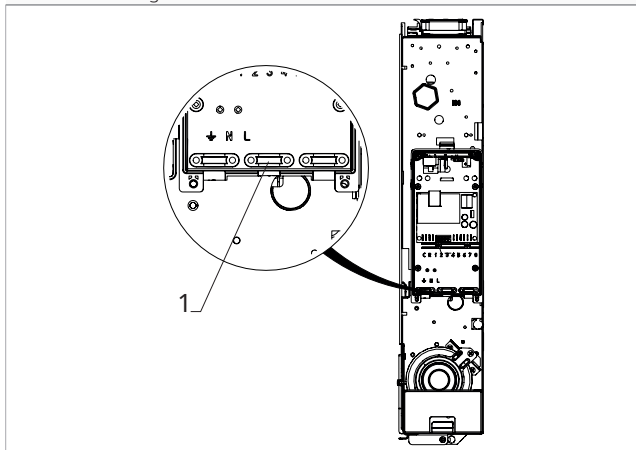

For fixing cables:

- ▶ use the cable glands provided
- ▶ fix the cables

5. MAINTENANCE

Routine maintenance is essential to keep the device efficient, safe, and reliable over time.

5.1 Preliminary warnings

⚠ This section is dedicated to the Authorised Service Centre. The features of the Authorised Service Centre are described in chapter "Recipients" p. 5.

Before each cleaning and maintenance intervention:

- ▶ Isolate and lock off the main supply, posting a notice indicating that work is being carried out.
- ▶ wait for the components to cool down in order to avoid any burns

⊖ Carrying out any technical or cleaning work before disconnecting the unit from the power supply is forbidden.

⚠ Make sure that there is no voltage before operating.

⚠ After completing the maintenance work, the unit must be restored its original condition.

⚠ Warnings:

- Do not lean or sit on the fancoil to avoid damaging the appliance.
- If water leaks from the device, you must switch it off immediately and disconnect the power supply. Then, call the nearest customer service centre.
- The device must not be installed in rooms where there are explosive gases or where there are conditions of humidity and temperature out of the limits defined in the installation manual.
- Clean the filter regularly.

5.2 Routine maintenance

The routine maintenance plan includes the following cleaning operations.

Carry out cleaning:

- every six months

Before each cleaning and maintenance intervention:

- ▶ Isolate and lock off the main supply, posting a notice indicating that work is being carried out.

⚠ Wait for the components to cool down in order to avoid any burns.

⚠ After completing the maintenance work, the unit must be restored its original condition.

⊖ It is forbidden to open the access doors and carry out any technical or cleaning intervention, before having disconnected the device from the mains supply by isolating and locking off the main supply, and posting a notice indicating that work is being carried out.

5.2.1 External cleaning

Clean the external surfaces using a soft cloth dampened with water.

⚠ Do not use abrasive sponges, or abrasive or corrosive detergents, as you might damage the painted surface.

⚠ Isolate and lock off the main supply, posting a notice indicating that work is being carried out.

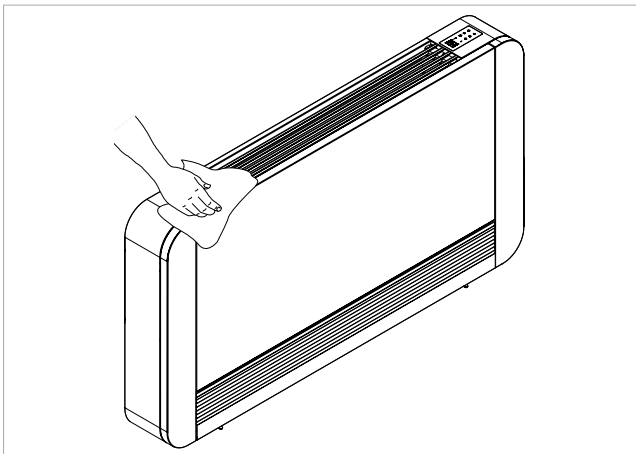

5.2.2 Air intake filter cleaning

Cleaning the filter must be carried out:

- after prolonged operation, consider the concentration of impurities in the air

- when you plan to restart the system after prolonged disuse

5.2.3 Filter extraction

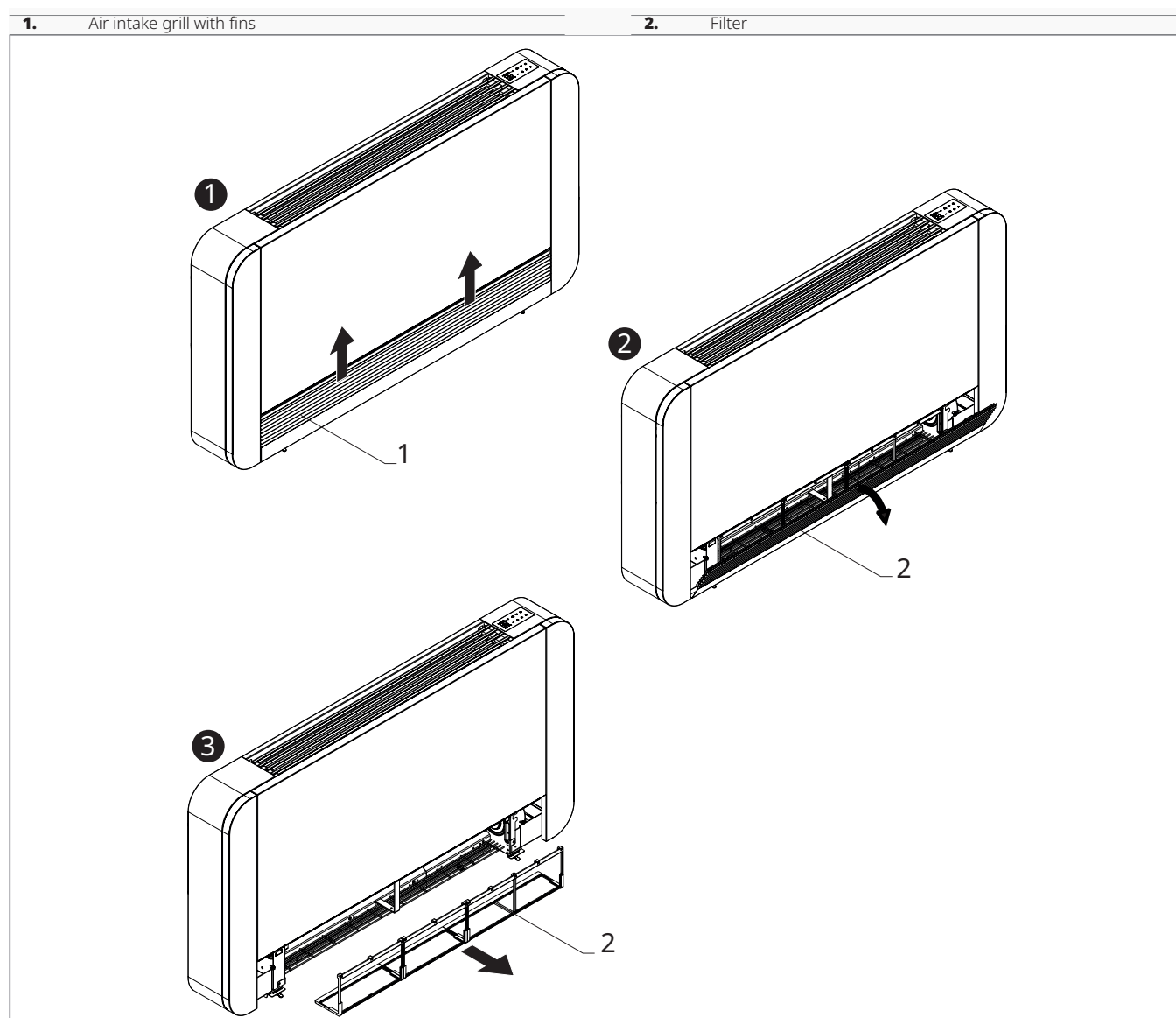

For removing the filter in versions with a finned intake grille:

- ▶ lift the fin grille slightly
- ▶ rotate the fin grille until it comes completely out of the housing
- ▶ remove the grille
- ▶ remove the filter

Cleaning the filters

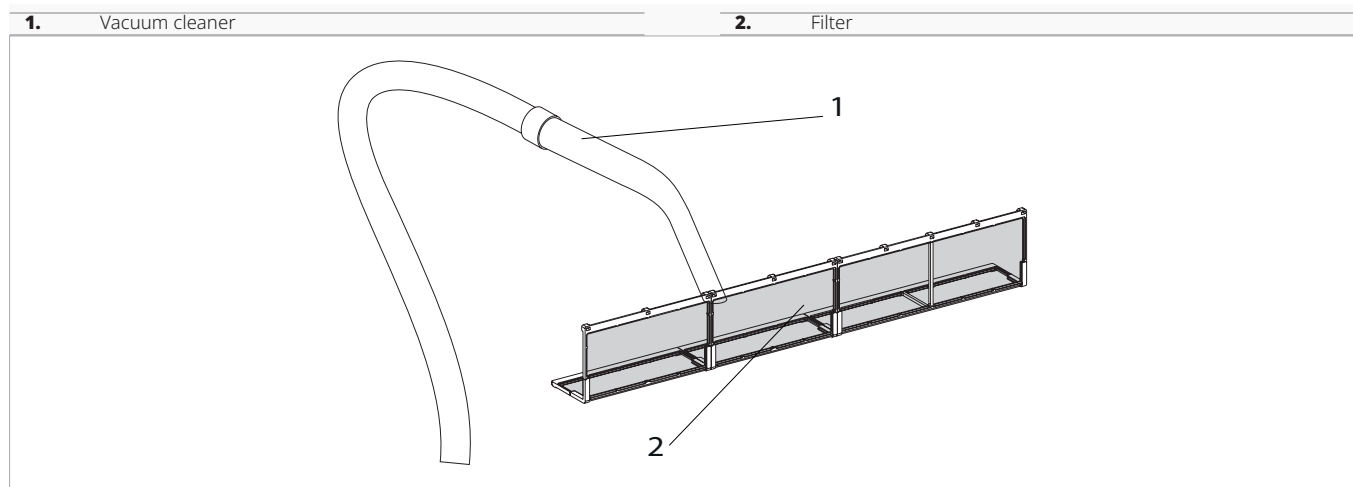

To clean the filter:

- ▶ use a vacuum cleaner

▶ aspirate dust

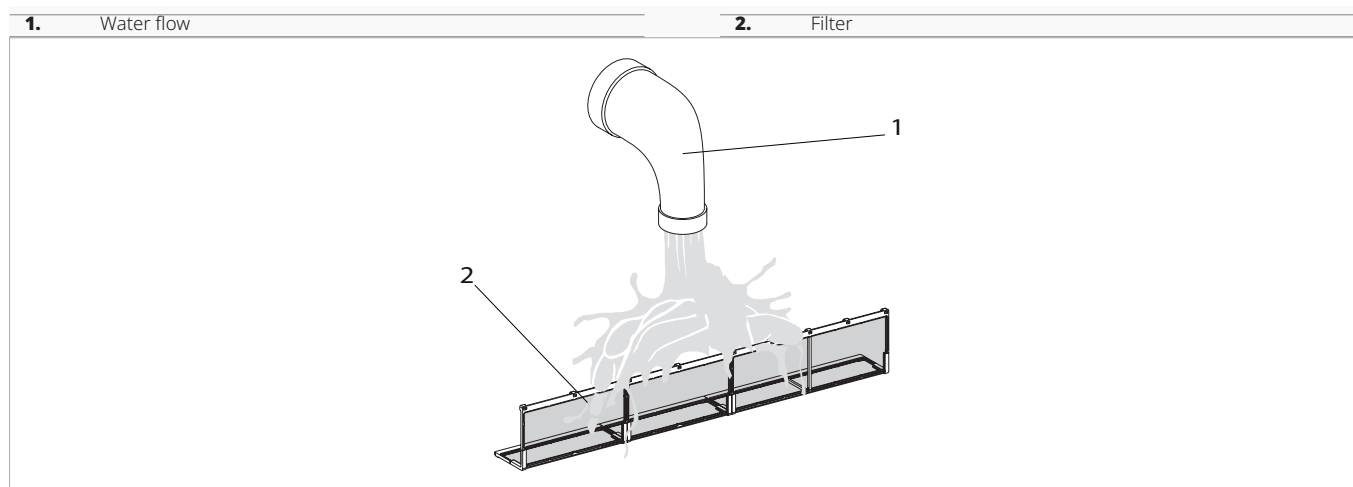

If the quantity of dust is considerable:

- ▶ wash the filter under running water (max. 40 °C)
- ▶ allow to dry in an area out of direct sunlight

⚠ Exposure to the sun or washing water temperatures above 40 °C can shrink the filters.

⊖ It is forbidden to use detergents or solvents to clean the filter.

Filter installation

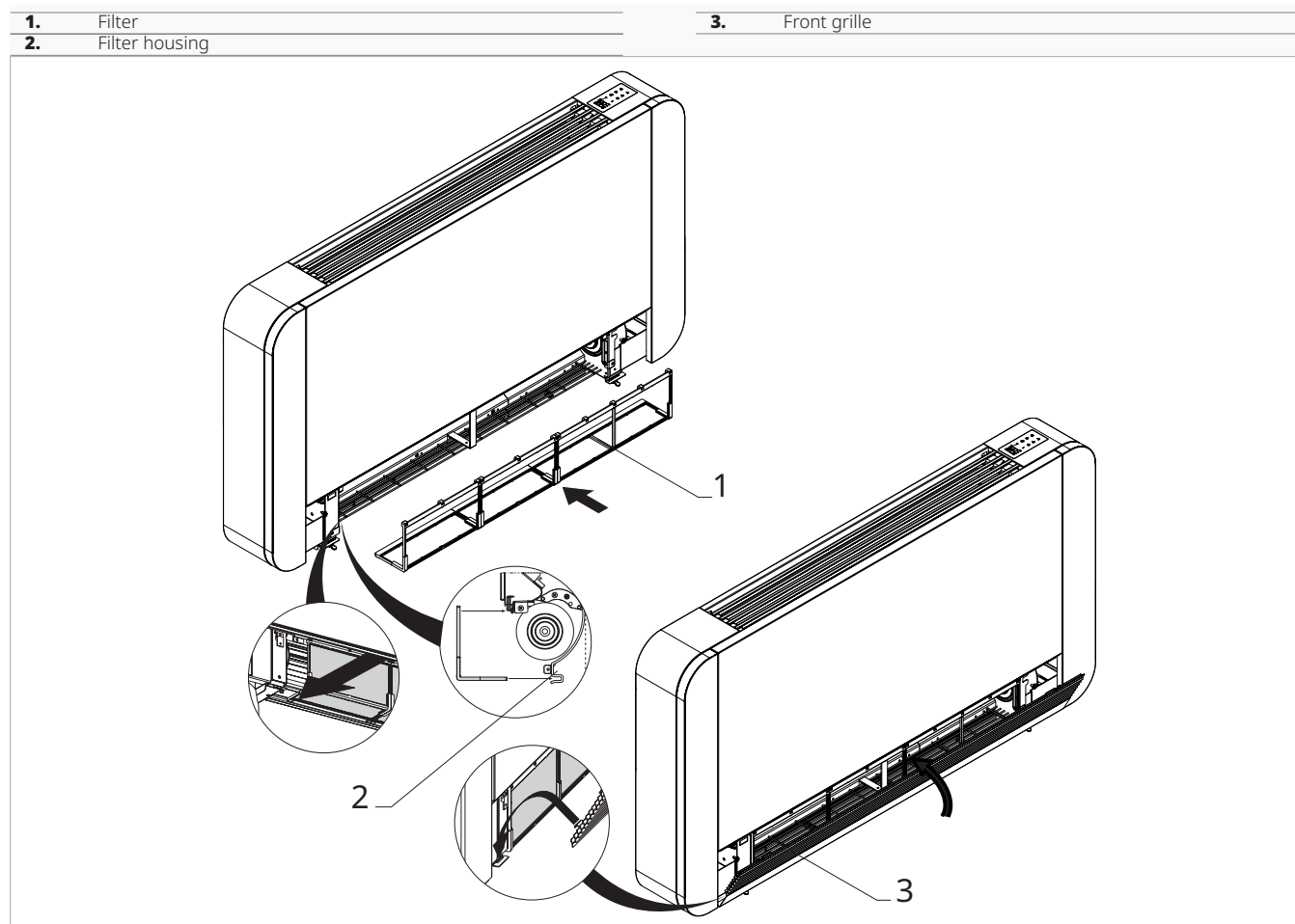

To reassemble the filter:

- ▶ bring the filter closer to the unit
- ▶ insert the filter into its housing
- ▶ bring the finned grille closer
- ▶ insert the grille into the appropriate slots

- ▶ rotating the grille
- ▶ hooking the grille

⚠ Check that the filter is fitted correctly.

⊖ It is forbidden to use the unit without a filter.

5.3 Suggestions for energy saving

For a correct operation of the device and a greater energy saving:

- keep the filters clean
- keep the doors and windows of the locations fitted with air conditioning systems closed as much as possible
- during summer limit the entry of direct sun rays into the rooms to be air-conditioned by means of external screens (projections, curtains, shutters, etc.)

6. TROUBLESHOOTING

6.1 Preliminary warnings

Should you encounter any of the anomalies below:

- the ventilation does not start even if the water circuit is filled with hot or cold water
- the device is losing water in heating mode
- the device is losing water in cooling mode
- the device generates excessive noise
- there is dew on the front panel

- ▶ disconnect the device from power supply immediately
- ▶ isolate the water supply
- ▶ immediately contact an Authorised Service Centre or suitably qualified personnel

⚠ The interventions must be carried out by a qualified installer or by an Authorised Service Centre.

Follow the instructions below:

⊖ Do not intervene personally.

6.2 Troubleshooting table

Effect	Cause	Solution
The ventilation is delayed with respect to the new temperature or function settings.	The circuit valve requires a certain time to open and therefore to make the hot or cold water circulate inside the device.	Wait 2 or 3 minutes to allow the circuit valve to open.
The device does not activate the ventilation.	Cold or hot water is missing from the system.	Ensure the heating or cooling source is on.
The ventilation does not start even if the water circuit is filled with hot or cold water.	The hydraulic valve stays closed.	Demount the body of the valve and check if the water circulation is restored. Check the valve operation, feeding it separately from a 230 V supply. If it operates, the problem may be in the electronic control.
	The ventilation motor is jammed or burnt.	Check the motor windings and check if the fan rotates freely.
	The micro switch that stops the ventilation when the filter grille is opened does not close properly.	Check that the closure of the grille activates the micro switch contact.
	The wirings are not correct.	Check the electrical connections.
The device is losing water in heating mode.	Leaks at the hydraulic connections of the system.	Check the leak and tighten the connection.
	Losses in the valve group.	Check the condition of the gaskets.
There is dew on the front panel.	Detached thermal insulation.	Check the correct positioning of the thermal and acoustic insulations paying particular attention to the front one located on top of the finned coil.
There are water drops on the air vent.	High humidity conditions (>60%) might generate condensation, especially at minimum ventilation speeds.	As soon as the level of relative humidity drops, the phenomena disappears. However, a few water drops falling inside the device will not cause any malfunction.
The device is losing water in cooling mode.	The condensate tray is clogged.	Slowly pour water in the lower section of the battery to check the drainage; if necessary clean the tray and/or improve the slope of the drain pipe.
	The condensate discharge pipe does not have the slope required for correct drainage.	
The device generates excessive noise.	The connection pipes and the valves unit are not well insulated.	Check the pipe insulation.
	The fan touches the structure.	Verify
	The fan is unbalanced.	The unbalancing generates excessive machine vibrations: replace the fan.
	Check the filters for dirt and clean them if necessary	Clean filters

7. TECHNICAL INFORMATION

7.1 Technical data

7.1.1 Technical data

Models	m.u.	P-FAL **					None					
		10	20	30	35	40	None	None	None	None	None	
Cooling performances (W 7/12 °C; A 27 °C) (1)												
Total cooling capacity		kW	0,91	2,12	2,81	3,30	3,71	0,91	2,12	2,81	3,30	3,71
Sensible cooling capacity		kW	0,71	1,54	2,11	2,65	2,90	0,71	1,54	2,11	2,65	2,90
Water flow		L/h	156,00	363,00	481,00	565,00	636,00	157,00	365,00	483,00	568,00	638,00
Pressure drop		kPa	12,10	8,20	17,10	18,00	21,20	12,10	8,20	17,10	18,00	21,20
Maximum absorbed power		W	11	19	20	29	33	11	19	20	29	33
Maximum sound power level	(2)	dB(A)	54	54	54	55	57	51	53	54	55	57
Heating performances (W 45/40 °C; A 20 °C) (3)												
Heating capacity		kW	1,02	2,21	3,02	3,81	4,32	1,02	2,21	3,02	3,81	4,32
Water flow		L/h	180,00	390,00	532,00	672,00	762,00	175,00	380,00	519,00	655,00	743,00
Pressure drop		kPa	9,10	9,20	19,10	21,20	23,30	9,10	9,20	19,10	21,20	23,30
Maximum absorbed power		W	11	19	20	29	33	11	19	20	29	33
Maximum sound power level	(2)	dB(A)	54	54	54	55	57	51	53	54	55	57
Hydraulic data												
Coil water content		L	0,47	0,80	1,13	1,46	1,80	0,47	0,80	1,13	1,46	1,80
Maximum operating pressure		bar	10	10	10	10	10	10	10	10	10	10
Hydraulic connections		" EK	3/4									
Aeraulic data												
Maximum air flow		m ³ /h	146	294	438	567	663	146	294	438	567	663
Medium air flow		m ³ /h	90	210	318	410	479	90	210	318	410	479
Minimum flow rate		m ³ /h	49	118	180	247	262	49	118	180	247	262
Static pressure available		Pa	10	10	13	13	13	10	10	13	13	13
Electrical data												
Power supply		V/ph/Hz	230/1/50									
Maximum absorbed current		A	0,11	0,16	0,18	0,26	0,28	0,11	0,16	0,18	0,26	0,28
Power consumption at the minimum speed		W	5,0	4,0	6,0	5,0	6,0	4,0	4,0	5,0	5,0	6,0
Sound data												
Sound pressure level at maximum air flow	(4)	dB(A)	41	42	44	46	47	41	42	44	46	47

1. Water temperature in coil inlet 7 °C, Water temperature in coil outlet 12 °C, Room air temperature 27 °C b.s. and 19 °C b.u. (according to EN 1397) - maximum speed and head 0 Pa
2. Sound pressure measured according to EN 16583
3. Water temperature in coil inlet 45 °C, Water temperature at coil outlet 40 °C, Room air temperature 20 °C b.s. and 15 °C b.u. (according to EN 1397) - maximum speed and head 0 Pa
4. Sound pressure measured at a distance of 1 meter according to ISO 7779

7. TECHNICAL INFORMATION

			P-FAL**					None				
Sound pressure level at medium air flow	(4)	dB(A)	33	34	34	35	38	33	34	34	35	38
Sound pressure level at minimum air flow	(4)	dB(A)	24	25	26	26	28	24	25	26	26	28

1. Water temperature in coil inlet 7 °C, Water temperature in coil outlet 12 °C, Room air temperature 27 °C b.s. and 19 °C b.u. (according to EN 1397) - maximum speed and head 0 Pa
2. Sound pressure measured according to EN 16583
3. Water temperature in coil inlet 45 °C, Water temperature at coil outlet 40 °C, Room air temperature 20 °C b.s. and 15 °C b.u. (according to EN 1397) - maximum speed and head 0 Pa
4. Sound pressure measured at a distance of 1 meter according to ISO 7779

7.2 Operating limits

Operating limits

		Heating	Cooling
Minimum water inlet temperature	°C	4	4
Maximum water inlet temperature	°C	80	80
Minimum room air temperature	°C	5	5
Maximum room air temperature	°C	32	32
Maximum water-side pressure	kPa	1000	1000

7.3 Dimensions

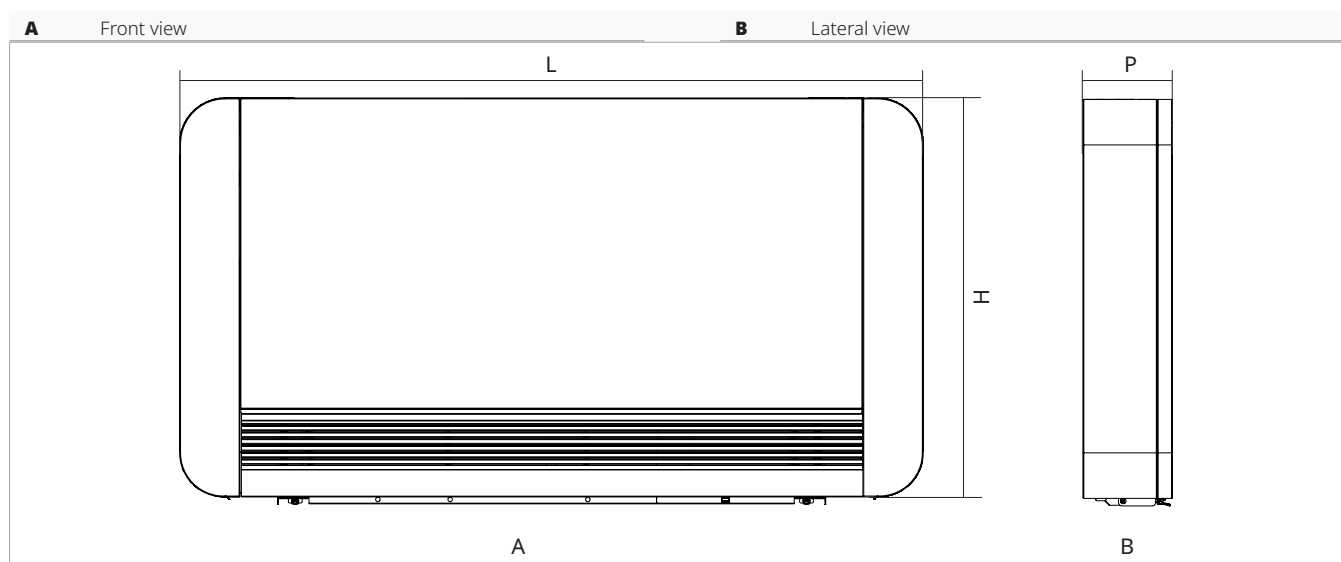

Models	m.u.	P-FAL**					None				
		10	20	30	35	40	None	None	None	None	None
Product dimensions and weight											
Width	mm	735	935	1135	1335	1535	680	880	1080	1280	1480
Height	mm	579	579	579	579	579	580	580	580	580	580
Total depth	mm	129	129	129	129	129	119	119	119	119	119
Net weight	kg	17,0	20,0	23,0	26,0	29,0	13,0	16,0	18,0	20,0	23,0

7.4 Installation template

⚠ The units are supplied with a paper template for marking the holes necessary for installation.

⚠ The template is unique for all sizes. For some sizes it is necessary to cut the template following the instructions within it.

1. Inlet position for installation with 3-way deviator valve (with fitting spacer)
2. Holes for dowels, \varnothing 8 mm
3. Inlet for installation with 2-way valve (with 90° fitting)
4. Top wire of the machine 65mm from the upper edge of the template
5. Outlet for hydraulic connections on the right with 2-way valve
6. Electrical connection area
7. Outlet for hydraulic connections on the right with 3-way valve

8. Hole \varnothing 8 for horizontal dowel
9. Condensate drain for hydraulic connections on the right
10. External perimeter of the machine
11. Space for pipe passage for connections on the right
12. Condensate drain
13. Outlet with 3-way valve
14. Outlet with 2-way valve
15. Electrical connection area for hydraulic connections on the right

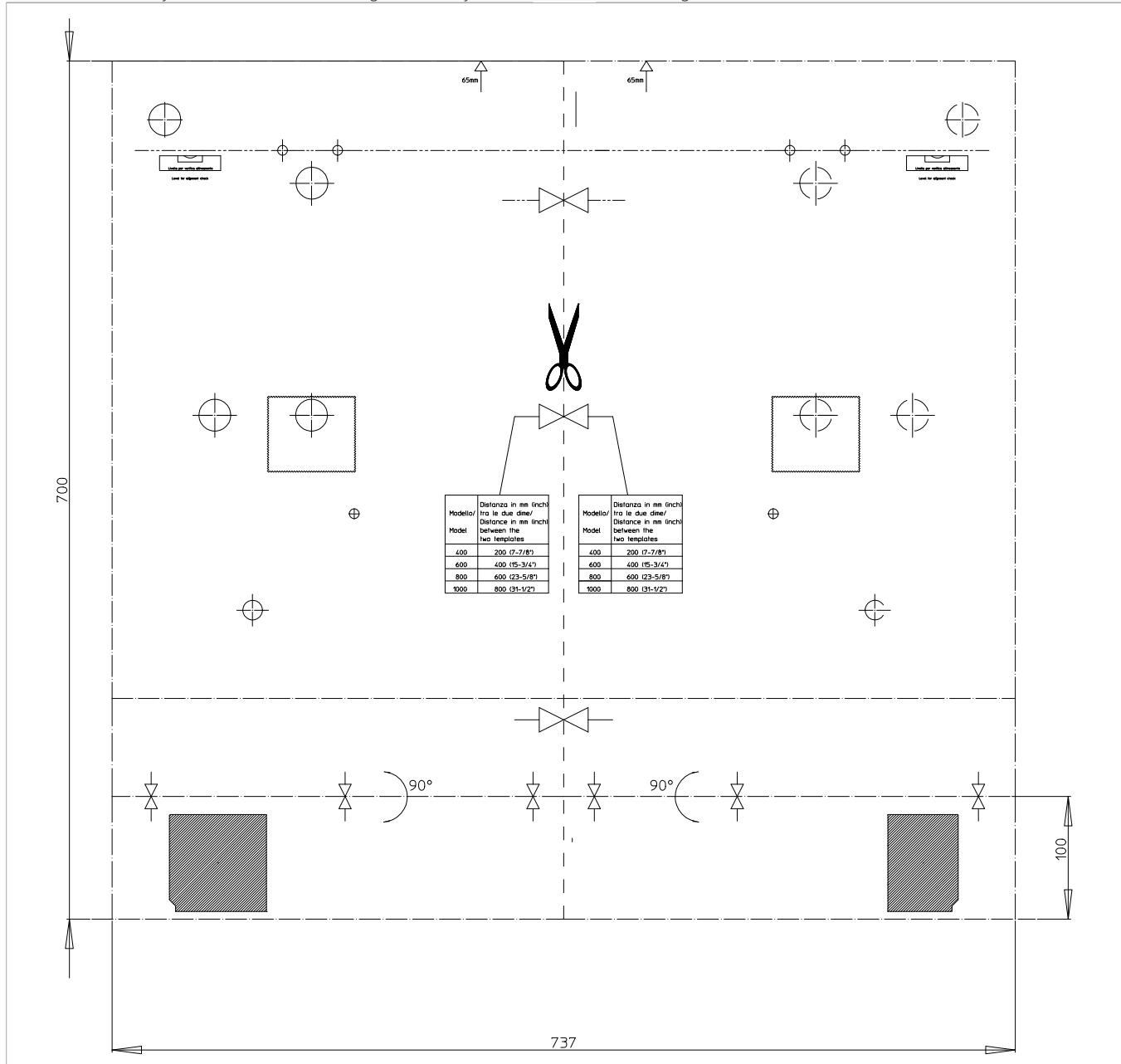

Panasonic[®]

Panasonic Corporation
1006 Kadoma, Kadoma City, Osaka, Japan